



# Solar-Based Polygeneration Systems for a Carbon Neutral Future with Focus on Hydrogen Production: A Comprehensive Review

G. S. Girishkumar<sup>1</sup>, M. R. Kamesh<sup>1</sup>, N. Shreekala<sup>2</sup>, D. Yogaraj<sup>3</sup>, M. Mohammed Nadeem<sup>4</sup>, B. R. Hemanth<sup>5</sup> and K. S. Nagaprasad<sup>6</sup>

<sup>1</sup>Department of Mechanical Engineering, Dayananda Sagar College of Engineering, Bengaluru-560078, Karnataka, India

<sup>2</sup>Department of Mechanical Engineering, Global Academy of Technology, Bengaluru-560098, Karnataka, India

<sup>3</sup>Department of Mechanical Engineering, Vel Tech Rangarajan Dr. Sagunthala R&D Institute of Science and Technology, Chennai-600062, Tamil Nadu, India

<sup>4</sup>Department of Mechanical Engineering, University of Greater Manchester, RAK Academic Centre, UAE

<sup>5</sup>Department of Mechanical Engineering, ATME College of Engineering, Mysuru-570 028, Karnataka, India

<sup>6</sup>Department of Mechanical Engineering, K.S. Institute of Technology, Bengaluru-560 109, Karnataka, India

†Corresponding author: G. S. Girishkumar; girishsachin010@gmail.com

**Abbreviation:** Nat. Env. & Poll. Technol.

**Website:** [www.neptjournal.com](http://www.neptjournal.com)

*Received:* 20-06-2025

*Revised:* 30-07-2025

*Accepted:* 25-08-2025

## Key Words:

Polygeneration system

Renewable energy

Sustainability

Carbon neutrality

## Citation for the Paper:

Girishkumar, G.S., Kamesh, M.R., Shreekala, N., Yogaraj, D., Mohammed Nadeem, M., Hemanth, B.R. and Nagaprasad, K.S., 2026. Solar-based polygeneration systems for a carbon-neutral future: A focus on hydrogen production: A comprehensive review. *Nature Environment and Pollution Technology*, 25(2), B4362. <https://doi.org/10.46488/NEPT.2026.v25i02.B4362>

*Note:* From 2025, the journal has adopted the use of Article IDs in citations instead of traditional consecutive page numbers. Each article is now given individual page ranges starting from page 1.



*Copyright:* © 2026 by the authors

*Licensee:* Technoscience Publications

This article is an open access article distributed under the terms and conditions of the Creative Commons Attribution (CC BY) license (<https://creativecommons.org/licenses/by/4.0/>).

## ABSTRACT

Solar-driven energy systems have made a significant contribution to accomplishing global sustainability goals and reducing greenhouse gas emissions and pollutant levels. The increase in the development of multigeneration systems is predominantly significant because these systems efficiently address the growing and diverse demands for energy. Simultaneously, hydrogen has emerged as a promising alternative fuel, garnering considerable attention for its potential to replace conventional energy sources. In addition to hydrogen, other distinctive outputs, such as power, heating, cooling, domestic hot water, and freshwater demands, can be met using this technology. As solar energy is used extensively for electricity and heat generation, photovoltaic–thermal (PVT) systems are emerging as highly reliable and capable approaches for sustainable energy solutions. This study emphasizes the inclusion of hydrogen production methods into polygeneration systems. Recent progress in concentrated photovoltaic-thermal and photovoltaic-thermal technologies, focusing on improvements in system performance. This study concludes that different system configurations and the incorporation of new technologies have significantly optimized PVT designs. Looking ahead, PVT systems offer a promising route for clean energy production. The integration of PVT and combined cooling, heat, and power (CCHP) technologies marks a transformative step toward achieving net-zero energy buildings and decarbonized energy systems, making them a crucial element in the global transition to clean and efficient energy production. Further progress in cost competitiveness could drive broader adoption. Additionally, it presents the growing demand to explore the potential of green hydrogen as an energy source and energy carrier. The study concludes that concentrated photovoltaic–thermal (CPVT) systems demonstrate outstanding performance in solar-based multigeneration applications, achieving energy efficiency as high as 78.93% and exergy efficiency of up to 65%. These high values underscore the capability of CPVT technology to effectively harness both electrical and thermal energy, making it highly suitable for integrated systems targeting hydrogen production, heating, and cooling.

## INTRODUCTION

The energy needs of a country are complex and serve as the foundation for economic growth, the development of social infrastructure, and the improvement of human living standards. Meeting these needs requires a dependable and sustainable energy supply system that offers extensive social, economic, and environmental advantages. Recently, there has been considerable research interest in polygeneration systems integrated setups that can produce various energy outputs (such as electricity, heating, cooling, hydrogen, etc.) from a single or

combined input source. While the idea of polygeneration has been around for many years, modern applications focus on achieving greater efficiency, reducing emissions, and optimizing resource use. A major driving force behind the adoption of polygeneration technologies is their capacity to utilize a range of energy resources, including both renewable sources (like solar, wind, biomass, and geothermal) and traditional fossil fuels (such as natural gas and coal) in hybrid setups. This combination enhances operational flexibility and boosts the sustainability of the overall energy system. The growing global population has significantly increased the demand for energy services. At the same time, the limited availability of fossil fuel reserves, along with rising concerns about climate change and environmental harm, has hastened the global transition to low-carbon and renewable energy technologies. In this shift, polygeneration systems play a crucial role by enabling the simultaneous production of multiple energy vectors, thereby reducing energy waste and maximizing the use of primary energy sources. Henceforth, it is essential to establish an energy-efficient system integrating with renewable energy sources to meet local energy demands and to achieve sustainability. PVT systems combine photovoltaic (PV) cells with thermal collectors in a single unit, enabling the concurrent production of electricity and thermal energy from solar radiation. This dual capability not only boosts the overall energy conversion efficiency of solar systems but also minimizes the land and material needs compared to using separate PV and solar thermal units.

In the realm of CCHP systems, PVT technologies are crucial. The electricity produced by the PV component can power building systems and appliances, while the thermal energy collected can be used in absorption chillers or heat exchangers for space cooling, heating, or domestic hot water production. This integrated method allows for year-round energy use, significantly enhancing the system's exergy efficiency and supporting the concept of tri-generation, which involves cooling, heating, and power from a single energy source. Furthermore, PVT-based CCHP systems are especially beneficial for residential, commercial, and institutional buildings, particularly in areas with high solar insolation. They decrease reliance on fossil fuels, reduce greenhouse gas emissions, and contribute to decentralized, sustainable energy infrastructures. When combined with energy storage and smart control systems, PVT-CCHP configurations can offer stable, dispatchable energy services tailored to changing demand patterns. Solar irradiation is regarded as highly reliable and could be converted into useful thermal energy or into a usable power source. A polygeneration system is an integrated energy

system that yields several energy outputs to fulfill local load demands. The allocation of total primary energy ingesting is around 31% worldwide, which is approximated to increase by an average value of 1.5% annually. In a world facing ever-increasing energy demands, polygeneration systems integrated with renewable energy sources represent a sustainable solution. To fully harness the potential benefits of polygeneration systems integrated with renewable energy, a holistic approach is essential.

The review highlights several significant knowledge gaps in the area of polygeneration systems, focusing on system integration, efficiency benchmarking, and techno-economic challenges.

#### *System Integration Challenges*

- Comprehensive analyses are scarce regarding the optimal integration of photovoltaic-thermal (PVT) systems within cooling, heating, and power (CCHP) frameworks.
- There is a lack of standardized frameworks or methodologies for combining renewable and conventional energy sources within polygeneration systems to address varying local energy needs.
- There is a lack of studies on smart control strategies and energy management systems that can dynamically optimize the real-time operation of PVT-CCHP systems.

#### *Efficiency Benchmarking Deficiencies*

- Few comparative studies have examined the exergy and energy efficiencies of polygeneration systems based on PVTs, compared to conventional or single-generation setups.
- The lack of universally accepted performance metrics and benchmarks for multi-output energy systems complicates cross-technology comparisons.
- Real-world performance validation and long-term efficiency tracking under diverse climatic and load conditions are lacking.

#### *Techno-economic barriers*

- An inadequate assessment of capital and operational costs, payback periods, and levelized cost of energy (LCOE) specific to integrated PVT-CCHP systems exists.
- There is limited data on the economic feasibility and scalability of such systems, especially for residential and institutional applications.
- Few policy analyses have explored the financial incentives, subsidies, and regulatory frameworks necessary to encourage widespread adoption.

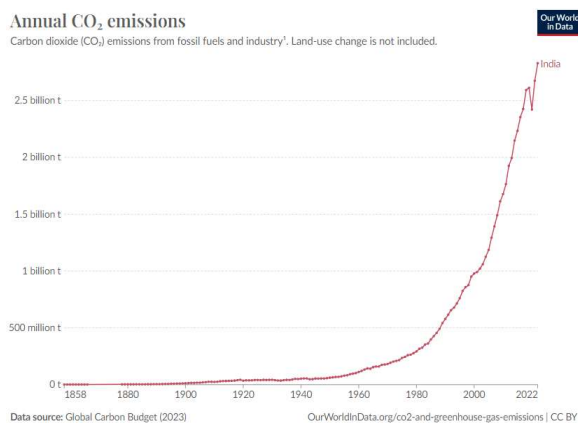

Fig. 1a: Annual carbon dioxide emissions.

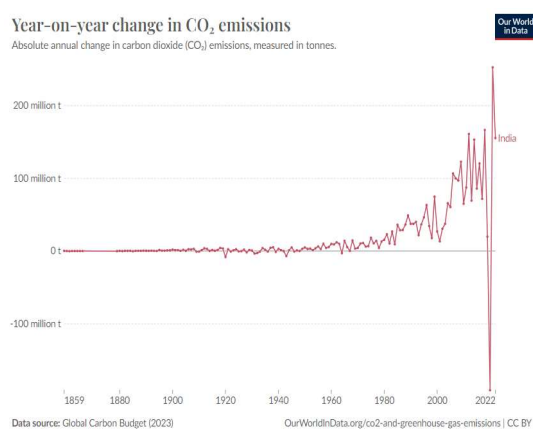

Fig. 1b: Year-on-year carbon dioxide emissions in India.

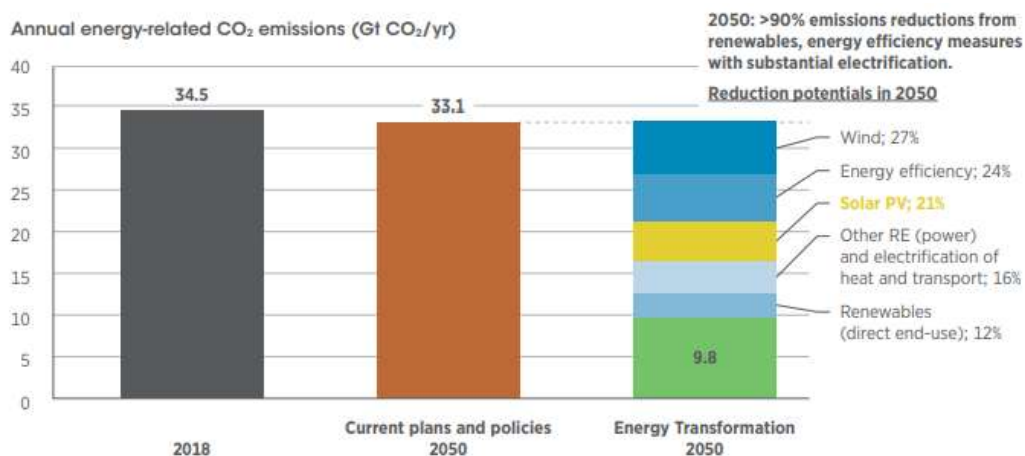

Fig. 1c: Overall energy-sector emissions reductions needed to meet Paris climate goals (<https://mnre.gov.in/2022-23>).

Table 1: Total electric power installations, sector-wise, from clean energy sources (MNRE 2023).

Sector	Installed Capacity (GW)	Under Implementation (GW)	Tendered (GW)	Total Installed/Pipeline (GW)
Solar Power	63.30	51.13	20.34	134.77
Wind Power	41.93	12.93	1.20	56.06
Bio Energy	10.73	---	---	10.73
Small Hydro	4.94	0.54	0.00	5.48
Hybrid/Round the Clock (RTC) /Peaking Power/Thermal + RE Bundling	---	---	11.06	11.06
Sub-Total	120.90	64.6	32.6	218.10
Large Hydro	46.85	14.15	---	61.00
Total	167.75	78.75	32.60	279.10

As shown in Figs. 1a and 1b, before the Industrial Revolution in 1850, the levels of emissions were minimal. However, emissions did not increase until the mid-20th century. As of 1950, 6 billion tons of CO<sub>2</sub> were emitted per year globally, but this had now risen to more than 20 billion tons by 1990. (Ritchie & Roser 2024).

India has planned to accomplish approximately half of its power consumption from renewable energy sources by 2023, according to the latest National Determined Contribution (NDC) updates. As of December 31, 2022, 167.75 GW of renewable energy capacity had been established in India. An additional 78.75 GW worth of projects were being

executed, and another 32.60 GW was at different stages of the bidding process. According to the REN21 Renewables 2022 Global Status Report, India ranks fourth in terms of renewable energy installed capacity, fourth in wind power capacity, and fourth in solar power capacity. Renewable energy installations have increased from 76.37 GW in 2014 to 167.75 GW in 2022, representing an increase of approximately 2.20 times (Table 1). Power generation from solar energy has also increased from 2.63 GW in 2014 to 63.30 GW in 2022 (<https://mnre.gov.in/2022-23>).

India receives a significant amount of direct normal irradiance (DNI), ranging from 4 to 7 kWh.m<sup>-2</sup> per day, highlighting the significant potential for decentralized solar energy applications, particularly through concentrating solar power (CSP) technologies. The major ways to harness solar power include providing heat for end-users and transforming it into electricity with PV cells, steam turbines, or any other technology after sunlight is absorbed by various collectors. Thus, the two main strategies involve solar PV and thermal electricity generation. Different solar technologies, including concentrating solar power (CSP) and photovoltaic (PV), have been widely described in many research studies. The abundance of solar energy with zero pollution makes it one of the most promising renewable sources; it has no associated cost. However, the popularization of large-scale solar power generation has been hindered by the fact that solar energy is not always available, leading to difficulties in its commercialization, thereby limiting its technological use (Wang et al. 2024a)

### **The Role of Renewable Energy in Polygeneration Systems**

A fast-tracked transition of our global energy infrastructure is critical to align ourselves with the Paris Agreement's aim of limiting global warming to below 1.5 °C within this century, as opposed to the levels that existed before large-scale industrialization. In addition, changing the world's energy system will enhance energy security and improve the availability of affordable and widespread energy access. This is important for countries that rely largely on imported fossil fuels (Soltani et al. 2023)

#### ***Environmental Benefits of Polygeneration Systems***

The integration of polygeneration systems in urban areas is seen as a promising route for addressing CO<sub>2</sub> mitigation problems. Polygeneration systems integrated with renewable energy sources offer a range of environmental benefits that are crucial for addressing the challenges of climate change and enhancing energy security.

#### ***Carbon Neutrality: Mitigating Climate Change***

Renewable energy sources are inherently carbon neutral, as

they emit no net carbon dioxide when producing energy. This characteristic aligns perfectly with the sustainability goals of polygeneration systems and contributes significantly to reducing the overall carbon footprint of energy production.

#### ***Energy Reliability: Diverse Resource Mix***

Polygeneration systems can benefit from the diversity of renewable energy sources. Energy systems with a combination of renewable energy sources become more resilient to fluctuations in resource availability. This reliability is particularly crucial in regions with variable weather patterns.

#### ***Localized Energy Production: Decentralization***

Renewable energy sources often enable decentralized energy production. This decentralization reduces the need for extensive transmission and distribution networks, thereby improving energy security and grid resilience. Furthermore, it empowers local communities to manage their own energy production.

## **MATERIALS AND METHODS**

This review adopts a systematic and thematic methodology to examine the present state and future potential of solar-based polygeneration systems, with a particular emphasis on hydrogen production for carbon-neutral purposes. An extensive literature review was conducted, spanning from 2012 to 2024, utilizing academic databases such as Scopus, Web of Science, IEEE Xplore, ScienceDirect, and Google Scholar. The search employed keywords such as solar polygeneration, PVT systems, CCHP, solar hydrogen production, photoelectrochemical hydrogen, thermochemical cycles, exergy analysis, and techno-economic evaluation. Studies were selected based on their relevance to integrated systems that produce multiple energy outputs, especially those involving solar PV/PVT technologies, while works focused solely on monogenerations or lacking practical validation were omitted. The selected literature was categorized into thematic areas: solar resource characterization, polygeneration configurations, hydrogen production methods, system integration and controls, efficiency and exergy performance, techno-economic and environmental assessments, and policy and deployment strategies.

### **Scope of Non-Conventional Sources-Based Hybrid Power Generation in India**

The need for clean and environmentally friendly alternatives has never been greater than it is now because of the growing consumption of energy and the problems associated with the shortage of fossil resources. Numerous renewable energy sources have been used in the past; however,

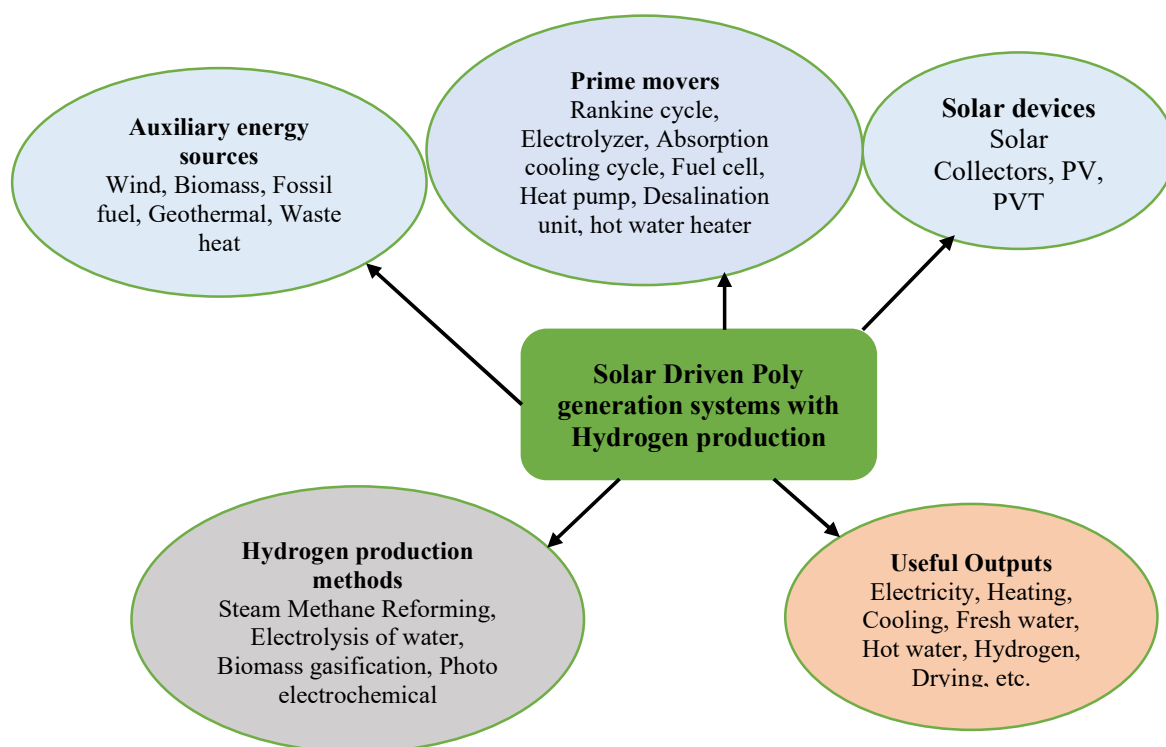

Fig. 2: Major components and useful outputs of typical solar-driven polygeneration systems.

they have always faced constraints related to economics, technological development, and many other factors. This is because a significant portion of these types of fuels is applied in contemporary electricity production systems that are not as efficient as they should be. India has a large agricultural and allied sector that accounts for a significant contribution to the country's economy, accounting for approximately 20% of the GDP and the largest source of employment, with over 50% of the population engaged in it. It offers a vast renewable biomass resource base to the country. Biomass has been a significant energy source in India. It is renewable, carbon-neutral, and can generate significant livelihood opportunities. However, to exploit its full potential, the availability of biomass in the country should first be assessed and quantified in diverse states. Highlighting the essence of this, the Ministry of New and Renewable Energy (MNRE) recently provided a study on the assessment of the country's biomass potential to the Administrative Staff College of India (ASCI), Hyderabad (MNRE 2023). The study estimated the surplus biomass availability of approximately 230 million metric tonnes per annum (2017–18) from agricultural residues and a biomass power potential of approximately 28 GW for the country. As per the report from ASCI for MNRE, the Biomass and Energy Management Division under Sardar Swaran Singh National Institute of Bioenergy (SSS-NIBE) has developed

the National Biomass Atlas to enable a better understanding of biomass availability in the country.

Solar biomass hybridization is a seasonal supplementation with two sources of energy. This is in addition to the fact that it originates from renewable energy sources. Comparatively, the biomass input energy consumption and feedstock are reduced by hybridization as compared to biomass only. The hybrid solar–biomass power plant might be most useful to enterprises connected with sugar cane, textile, chemicals, petrochemicals, and commercial power attraction (Sharifishourabi et al. 2024).

### Typical Polygeneration System

Fig. 2 displays a block diagram of a typical polygeneration system. The energy requirements of heating, cooling, power, and other beneficial outputs, such as hydrogen, can be satisfied by this system. As the construction sector accounts for approximately 40% of worldwide energy consumption, power, heating, and cooling are the most prevalent energy demands (Soltani et al. 2023). A polygeneration unit is essentially composed of at least one primary mover. This device is typically used to generate electricity and is powered by fuel or heat input (Fig. 3).

### Efficiency Definitions in Polygeneration Systems

Polygeneration systems are evaluated based on energy and exergy efficiency standards.

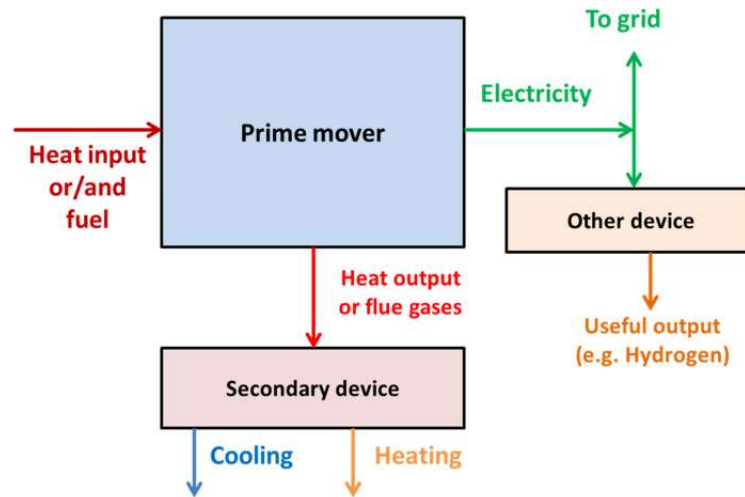

Fig. 3: Typical Polygeneration system (Kasaieian et al. 2020).

$\eta_{en}$  is defined as the energy yield ( $E_{n, out}$ ) in relation to energy intake ( $E_{n, in}$ ):

$$\eta_{en} = (\sum E_{n, out}) / (\sum E_{n, in}) \quad \dots(1)$$

Similarly, the exergy efficiency ( $\eta_{ex}$ ) is defined as the exergy yield ( $E_{x, out}$ ) versus energy intake ( $E_{x, in}$ ).

$$\eta_{ex} = (\sum E_{x, out}) / (\sum E_{x, in}) \quad \dots(2)$$

A typical solar-driven ( $Q_s$ ) and heat input ( $Q_{aux}$ )-trigeneration system is designed to produce electricity ( $P_{el}$ ), heat ( $Q_{heat}$ ) at  $T_{heat}$ , and cooling ( $Q_{cool}$ ) at  $T_{cool}$ .

The energy efficiency of the aforementioned system can be determined using Equation (2).

$$\eta_{en} = (Q_{heat} + Q_{cool} + Q_{el}) / (Q_s + Q_{aux}) \quad \dots(3)$$

The exergy efficiency of the above-considered system can be determined using (2) Equation.

$$\eta_{ex} = (Q_{heat} (1 - T_0 / T_{heat}) + Q_{cool} (T_0 / T_{cool} - 1) + P_{el}) / (E_{x, s} + E_{x, aux}) \quad \dots(4)$$

The ambient temperature ( $T_0$ ) is often set to 298.15 K, whereas the temperature levels ( $T_{heat}$ ) and ( $T_{cool}$ ) are expressed in Kelvin units.

The Petela model (Kasaieian et al. 2020) can be used to determine the exergy flow from solar irradiation ( $E_{x, s}$ ).

$$E_{x, s} = Q_s [1 - 4/3 T_0 / T_{sun} + 1/3 ((T_0 / T_{sun})^4)] \quad \dots(5)$$

where  $T_{sun} = 5770$  K is the temperature of the Sun and is the mean temperature of the outer layer.

### Pathways for Polygeneration Energy Systems

The integration of renewable energy sources to produce and meet energy demands is a key feature of polygeneration

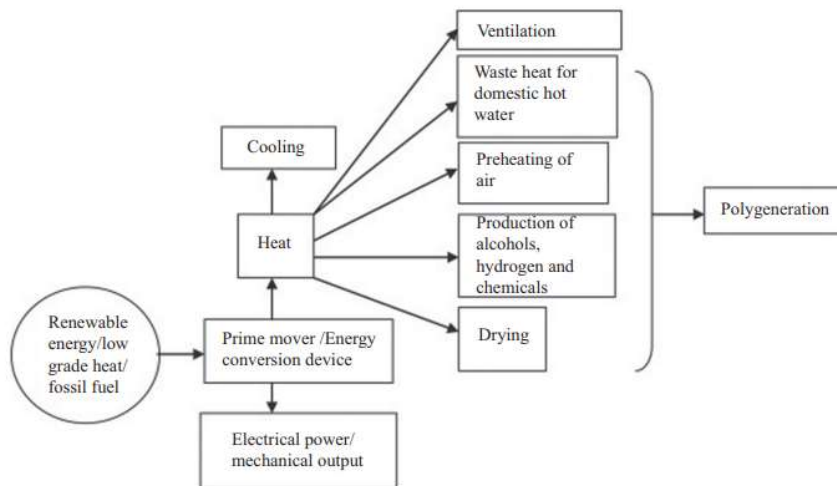

Fig. 4: Possible pathways of polygeneration systems (Lebepe et al. 2025).

systems (Fig. 4). Depending on the power range, application, and cost considerations, the most suitable prime mover and mechanism for converting energy are chosen. Current research studies include the following: (i) using renewable energy units as much as possible in homes, offices, and factories; (ii) using various sources of power to run fuel cells; (iii) optimal design of a polygeneration network; and (iv) several options for such systems in terms of their application within residential areas, commercial buildings, and factories.

Polygeneration systems can utilize prime movers, such as Sterling engines, reciprocating engines, steam engines, and organic Rankine cycles, as well as gas turbines and micro-gas turbines, to generate power and heat (Fig. 5).

The shaded areas indicate absorption owing to atmospheric constituents, mainly  $\text{H}_2\text{O}$ ,  $\text{CO}_2$ , and  $\text{O}_3$ . The wavelengths potentially utilized in different solar energy applications are indicated at the top.

India is currently undergoing a rapid transition in its renewable energy sector, driven by the pressing need to reduce carbon emissions, bolster energy security, and satisfy increasing energy demands. Situated in a solar-rich tropical

zone, India benefits from an average solar insolation of  $4\text{--}7 \text{ kWh}\cdot\text{m}^2\cdot\text{day}^{-1}$  over 280–300 clear-sky days annually, equating to more than 5,000 TWh of solar potential annually. This abundant resource underpins solar-based polygeneration systems, which provide electricity, heat, cooling, and hydrogen from a single, integrated platform. Fig. 6 depicts solar spectral irradiance, emphasizing the 400–2500 nm range, in which the majority of solar energy is concentrated. This range is crucial for key solar technologies, such as photovoltaic, photo-thermal, and photochemical hydrogen processes. Photovoltaic-thermal (PVT) systems are particularly efficient in this range, capturing both electrical and thermal energy, thus enhancing system-level energy and exergy efficiency while reducing land usage. India's goals—500 GW of non-fossil capacity by 2030 and 5 MTPA of green hydrogen under the National Green Hydrogen Mission—underscore the strategic importance of harnessing this solar potential. Combining solar energy with hydrogen production through photochemical, thermochemical, or PV/PVT-powered electrolysis provides a scalable approach to decarbonize the transport, industrial, and power sectors.

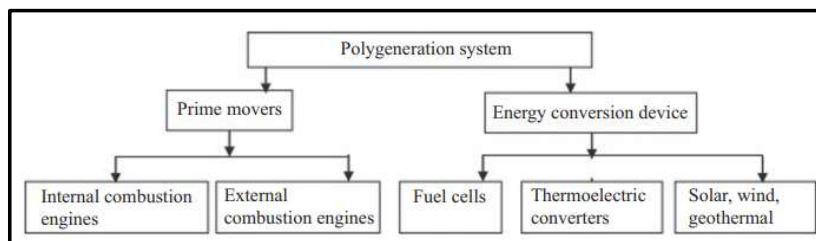

Fig. 5: Various prime movers and energy conversion devices in polygeneration systems (Lebepe et al. 2025).

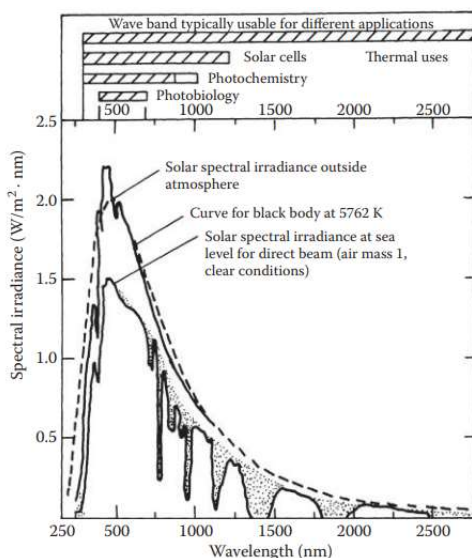

Fig. 6: Spectral irradiance curves for direct sunlight are for extraterrestrial and sea-level conditions with the sun directly overhead.

This review emphasizes the alignment between solar-based polygeneration systems and India's long-term carbon neutrality objectives.

## Overview of Solar Energy Technologies

### Solar Collectors

Solar collectors receive solar radiation and convert it into thermal energy (thermal collectors), or with some collectors providing both outputs (photovoltaic–thermal [PVT]). Focusing and non-focusing (or flat) collectors are the two types of solar collectors (Fig. 7). Concentrating technologies have a concentrating surface that expands the effective aperture and directs sunlight onto the receiver over a small area. Concentrating collectors are frequently

used in conjunction with other thermal devices because they typically function at higher temperatures than flat collectors.

Solar energy technologies capture plentiful and renewable power from the sun and transform it into usable forms, such as electricity, heat, or chemical fuels. These technologies are generally divided into photovoltaic (PV), concentrated solar power (CSP), and photovoltaic-thermal (PVT) hybrid systems, each with unique operating principles, applications, and efficiency traits.

### Photovoltaic (PV) Systems

PV systems directly convert solar radiation into electricity via the photovoltaic effect in semiconductor materials.

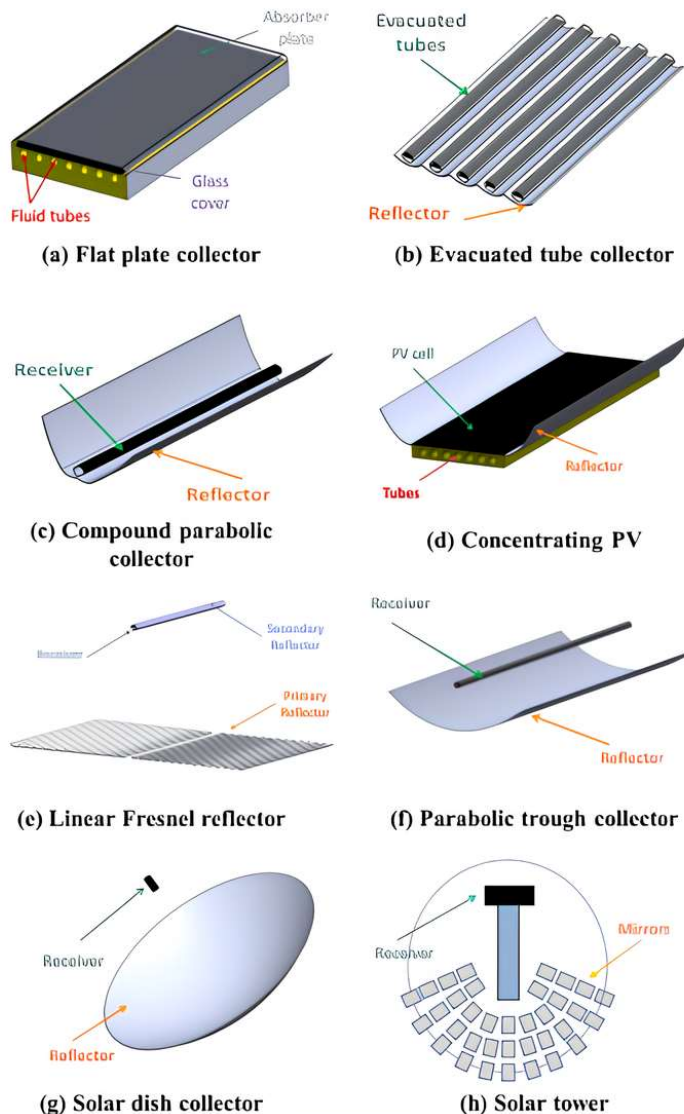

Fig. 7: Common types of solar collectors (Kasaieian et al. 2020).

Common PV technologies include crystalline silicon (c-Si) PV, which dominates the market (~90%) owing to its maturity, reliability, and relatively high efficiency (15–22%). Thin-film PV: This category includes amorphous silicon (a-Si), cadmium telluride (CdTe), and CIGS (Cu (In,Ga) Se<sub>2</sub>). These are lighter and cheaper to manufacture but generally have lower efficiency. Emerging PV technologies: These include perovskite solar cells, quantum dot PVs, and organic PVs, which are promising for their tunability and low-cost processing, although they are still in development. PV systems are modular and scalable, making them suitable for grid-connected and standalone (off-grid) applications.

**Concentrated solar power (CSP) systems:** CSP technologies use mirrors or lenses to focus direct sunlight onto a receiver to generate high temperatures, which are then used to produce steam and drive a turbine for electricity generation. CSP systems include parabolic trough collectors (PTCs), linear Fresnel reflectors (LFERS), solar power towers (central receivers), and parabolic dishes. CSP systems are ideal for utility-scale applications in regions with high direct normal irradiance (DNI) and can incorporate thermal energy storage (TES), such as molten salts, to provide dispatchable power.

**Photovoltaic-thermal (PVT) hybrid systems:** PVT systems combine PV modules with solar thermal collectors to simultaneously produce electricity and useful heat. The thermal collector removes excess heat from the PV cells, thereby enhancing the electrical efficiency and extending the module lifespan.

Types of PVT systems include air-based, water-based, and concentrated PVT (CPVT) systems. PVT systems are particularly effective in applications that require both thermal and electrical outputs, such as polygeneration, building-integrated systems, and solar-assisted heating/cooling.

**Solar-to-fuel technologies (Advanced):** Emerging technologies convert solar energy into chemical fuels, such as hydrogen, through processes such as photoelectrochemical (PEC) water splitting, solar thermochemical cycles, and solar-powered electrolysis. These technologies are crucial for long-term strategies for solar-based fuel generation and storage, aligning with decarbonization and hydrogen economy goals.

### Solar-Driven Multi-Generation Units

To address the varied requirements of contemporary society, systems that may provide several beneficial outputs have been developed in recent decades to improve the efficient use of natural resources and lower carbon emissions. In addition to producing electricity, tri-generation systems that incorporate cooling (also known as combined cooling, heat, and power, or CCHP) units, and combined heat and power

(CHP) or cogeneration units have established themselves as technologies. Furthermore, systems known as multi-generation (MG) or polygeneration have been introduced to generate more than three outputs, including chemicals, hydrogen, and freshwater, in addition to electricity, heat, and cooling. Renewable energy sources or traditional fossil fuels can power these systems. Because of their efficiency and sustainability, solar-powered MG setups have attracted much attention from academics, researchers, and industry.

### Hydrogen as an Output

Hydrogen is becoming an essential element in the worldwide shift towards carbon-neutral energy systems, offering a clean, adaptable, and high-energy-density option across multiple sectors. When generated through electrolysis powered by renewable energy, known as green hydrogen, it facilitates the decarbonization of energy consumption without producing direct greenhouse gas emissions. As an energy carrier rather than a primary energy source, hydrogen enables the storage and transportation of excess renewable energy, thus addressing the variability of solar and wind power. Its importance is particularly notable in sectors that are difficult to electrify, such as heavy industry, long-distance transportation, and high-temperature industrial processes, where direct electrification is often impractical. In solar-based polygeneration systems, hydrogen production improves system integration and efficiency by using surplus electricity or thermal energy to drive water-splitting processes. Additionally, hydrogen can be stored and later utilized in fuel cells or gas turbines for electricity generation, allowing for long-term energy storage and grid stabilization. The environmental advantages are significant, as green hydrogen eliminates carbon emissions at the point of use, supports the circular carbon economy, and aids in meeting international climate goals. With decreasing costs of solar power and electrolysis technologies, along with growing policy support, hydrogen is set to play a transformative role in fostering a resilient, multi-sectoral, and low-carbon energy future. The methods available for hydrogen production are shown in Fig. 8.

**Steam methane reforming:** Methane (CH<sub>4</sub>) reacts with steam to produce hydrogen.



The reaction is endothermic in nature, and this process requires a large amount of steam and a high operating temperature (700–900°C). Because of its cost and temperature and chemical characteristics, the SMR process generally occurs in a reformer with several tubes filled with a catalyst, typically nickel, supported by alumina (Al<sub>2</sub>O<sub>3</sub>) particles. The water-gas shift (WGS) reaction converts synthesis gas, particularly carbon monoxide, to carbon dioxide, as shown below.

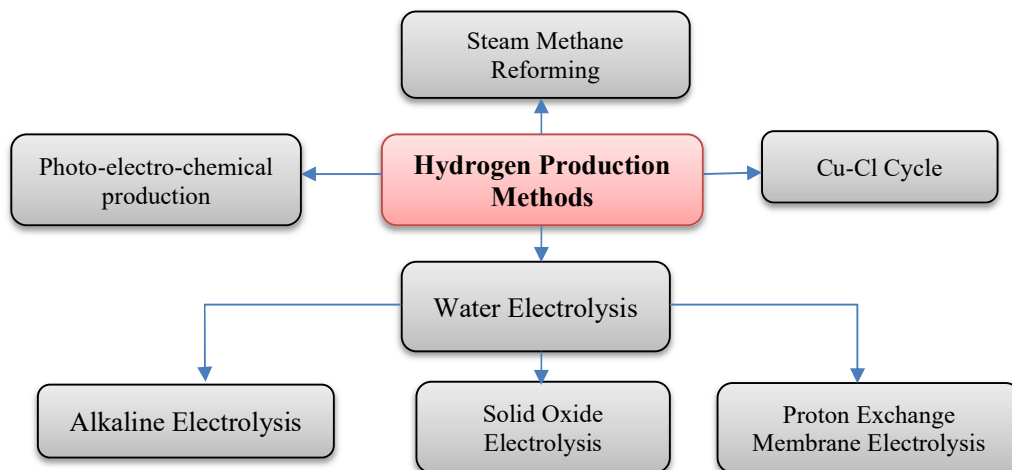
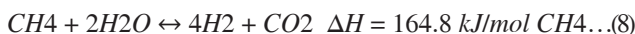

Fig. 8: Methods for hydrogen production.



This two-stage, slightly exothermic process lowers carbon monoxide (CO) molecules and generates more hydrogen. Nickel catalyzes the first stage, which requires higher temperatures (300–450°C), whereas copper catalyzes the second stage, which is conducted at lower temperatures (200–250°C). The following equation provides the overall reaction:



Pressure-swing adsorption (PSA) is used to segregate the resulting gas mixture and produce hydrogen with > 99.999% purity. SMR is the most economical, extensively used, and energy-efficient method for producing hydrogen. Currently, steam reforming of natural gas is the main process for hydrogen production.

### Green Hydrogen Via Water Electrolysis

Green hydrogen is becoming a main carrier of the global shift, given the growing commitment to combat climate change and avoid dependence on fossil fuels. Solar hydrogen synthesis via electrolysis is one of the most promising methods for utilizing green hydrogen and lowering carbon dioxide emissions (Moraba et al. 2025).

Green hydrogen refers to hydrogen generated by the electrolysis or photo-catalysis of water with a renewable energy source as the input. In this technique, the carbon footprint can be very low; however, using fossil fuels can significantly increase it. If carbon capture and storage is performed, the hydrogen is referred to as blue hydrogen, and the cost associated with this is higher than that of gray hydrogen. However, the cost incurred for green hydrogen production is huge because of the electrolysis cells and power from renewable energy sources. This prevents green hydrogen from being produced on a large scale. Both technology advancements and regulatory assistance are

encouraging low-carbon approaches to become more cost-effective in the pursuit of carbon neutrality (Hu et al. 2025). The methods of hydrogen production are depicted in Fig. 9.

The working principle through a schematic representation of alkaline, proton exchange membrane, and solid oxide electrolyzers is shown in Fig. 10.

This process, which includes the splitting of water molecules, produces hydrogen in a clean, carbon-free manner. Energy, usually in the form of heat or electricity, is required for this highly endothermic process and can be produced from renewable resources. Alkaline electrolysis, solid oxide electrolysis, and proton exchange membrane (PEM) electrolysis are the electrolysis techniques that are currently being developed and marketed (Table 2).

Proton exchange membrane (PEM) electrolysis uses a solid polymer electrolyte, such as Nafion™, whereas alkaline electrolyzers use a liquid alkaline electrolyte, such as potassium hydroxide (KOH) or sodium hydroxide (NaOH). Although solid oxide electrolyzer cell (SOEC) systems require thermal energy at higher temperatures, both require electrical input. PEM electrolysis is typically employed in small-scale plants, whereas alkaline electrolysis is suitable for medium- and large-scale facilities. PEM cells can adapt to the varying electricity from renewable sources, occupy less space, and exhibit superior dynamic performance. These cells deliver improved efficiency and purity of hydrogen; however, they are expensive.

For PEM electrolysis; Anode;  $2H_2O \rightarrow O_2 + 4H^+ + 4e^-$



For alkaline and solid oxide electrolysis:

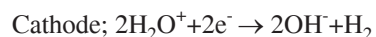
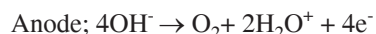

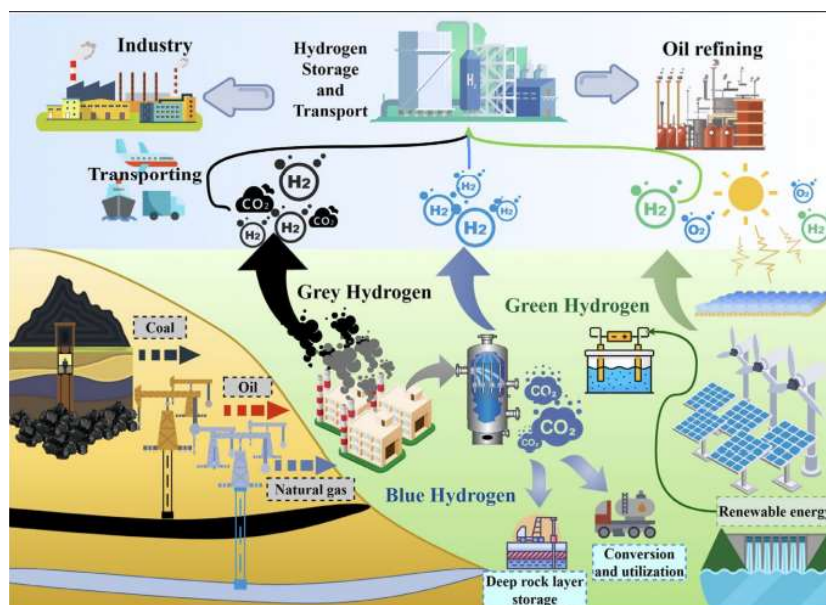

Fig. 9: Overview of hydrogen production pathways; grey (from fossil fuels), blue (with carbon capture and storage), and green (from renewable energy) along with storage, transport, and industrial applications enabling a low-carbon energy transition (Hu et al. 2025).

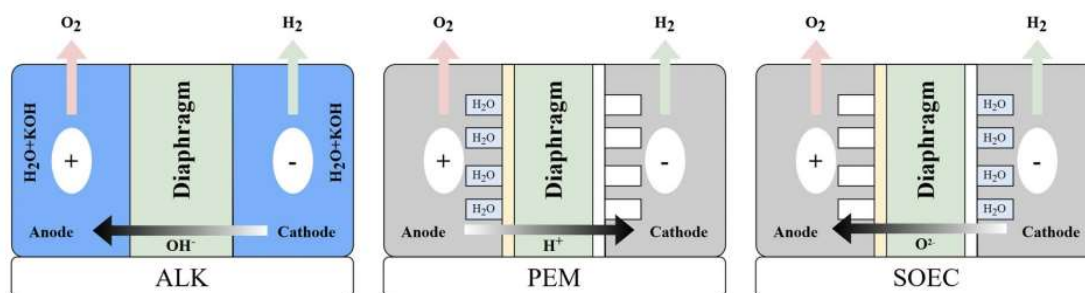

Fig. 10: Schematic comparison of three main water electrolysis technologies, alkaline (ALK), proton exchange membrane (PEM), and solid oxide electrolysis cell (SOEC), illustrating ion transport mechanisms, electrode reactions, and gas outputs for hydrogen production (Bozgeyik et al. 2022).

Table 2: Types of electrolyzers.

Sl. No.	Electrolyzers	Operating Temperature	Advantages	Applications
1.	Proton Exchange Membrane (PEM)	50–80°C	High hydrogen purity (99.999%) Compact and efficient Fast response to power fluctuations	Renewable energy integration Transportation Small to medium-scale industrial use
2.	Alkaline Electrolyzers	60–80°C	Lower capital cost than that of a PEM. Proven mature technology Long operational lifespan	Large-scale industrial hydrogen production Chemical processes (ammonia, methanol production) Steelmaking
3.	Solid Oxide Electrolyzers (SOE or SOEC)	700–1,000°C	Highest efficiency (up to 90%) can utilize waste heat from industrial processes. Compatible with CO <sub>2</sub> electrolysis for synthetic fuels	Industrial heat and hydrogen integration Power-to-gas and synthetic fuel production Energy storage
4.	Anion Exchange Membrane (AEM) Electrolyzers	50–70°C	Combines benefits of PEM and alkaline technologies Lower cost due to non-precious metal catalysts Safer operation (no liquid electrolytes)	Distributed hydrogen generation Decentralized energy applications

Technologies for manufacturing hydrogen have advanced significantly, especially in the area of green hydrogen production from renewable resources. Solar radiation provides a clean and renewable energy source with enormous potential to satisfy many contemporary demands. This energy can be used to generate heat using solar thermal collectors or electricity using photovoltaic cells. Because solar collectors can produce heat at different temperatures, they are a promising and adaptable technology that is perfect for incorporation into polygeneration systems.

Fuel cell-powered vehicles, where hydrogen is the fuel input of such devices, are most likely to replace existing EVs that require charging the battery using power supplied by traditional grids. The charging duration of batteries used in EVs, such as lithium-ion batteries (LIBs), is longer, and there is a risk of explosion owing to overheating or short circuits,

along with a limited battery cycle life. The adoption of fuel cell-powered vehicles is essential.

### Methodology of Hydrogen production in Multi-generation Systems

#### *PTC Based MG Systems With Hydrogen Production*

Parabolic trough collectors (PTC) may function at temperatures as high as 400–500°C, they have been the subject of numerous studies in the literature on polygeneration systems. Consequently, this type of collector can accommodate a variety of setups. PTCs are typically used in conjunction with biomass boilers to provide uninterrupted heat throughout the day, particularly when solar energy is scarce. Absorption heat pumps are frequently incorporated into the system to generate heating or cooling. Internal combustion engines, gas turbines, and

Table 3: PTC-based MG Systems.

Study	Components	Results
Almahdi et al. 2016	Biomass belt dryer, TES, PEMWE, ORC, ACC and HP	Energy Efficiency = 20.7% Exergy Efficiency = 21.7% Mass of hydrogen = 0.001693 kg.s <sup>-1</sup>
Mahmood et al. 2021	ORC, PEMWE, TES, hydrogen-oxy combustor, ACC, desalination unit	Energy Efficiency = 41% Exergy Efficiency = 28.4% Mass of hydrogen = 0.01 kg.s <sup>-1</sup>
Tukenmez et al. 2020	ORC, PEMWE, TES, hydrogen compression system, desalination unit, KC, ejector cooling cycle, dryer, and DHW heater.	Energy Efficiency = 59.34% Exergy Efficiency = 56.51% Hydrogen = 0.0043 kg.s <sup>-1</sup>
Ozlu et al. 2016	PEMWE, TES, Rankine Cycle, desalination unit, water heater	Energy Efficiency = 36% Exergy Efficiency = 44% Hydrogen=0.63 kg.s <sup>-1</sup>
Bamisile et al. 2020	Rankine Cycle, ACC, PEMWE, DHW heater	Energy Efficiency = 71.6% Exergy Efficiency = 24.5% Hydrogen = 0.9785 kg.s <sup>-1</sup>
Bozgeyik et al. 2022	ORC, PEMWE, DHW heater, desalination unit	Energy Efficiency = 78% Exergy Efficiency = 25.50% Amount of hydrogen = 20.39 kg.day <sup>-1</sup>
Shabani et al. 2024	ORC, Brayton cycle, MED, PEMWE, Kalina cycle, ejector cooling.	Energy Efficiency = 38.45% Exergy Efficiency = 35.64%
Qing et al. 2024	TES, dual-pressure organic rankine cycle (DORC), compression refrigeration system (CRC), PEMWE, and Claude hydrogen liquefaction unit (CHL).	Power = 13.45 MW Cooling = 3.41 MW Hydrogen = 27.3 kg.h <sup>-1</sup> SPP = 5.77 years.
Gursoy et al. 2024	Power cycles (steam and organic Rankine cycles), MED, PEMWE, hydrogen storage and refueling	Energy Efficiency = 15.83% Exergy Efficiency = 16.61%
Temiz et al. 2024	TES, RC and ORC	Energy Efficiency = 31.29% Exergy Efficiency = 19.71%
Koc et al. 2024	Desalination unit, Gas turbine, PEMWE	Energy Efficiency = 55.91% Exergy Efficiency = 49.19%
Luqman et al. 2020	RC, MSF, wind turbine, desalination unit, PEMWE, a refrigeration unit, drying unit for food, a combustor, water heater, and storage units.	Energy Efficiency = 50% Exergy Efficiency = 34% Fresh water 828 m <sup>3</sup> .day <sup>-1</sup> Hot air = 36 kg.s <sup>-1</sup> Hot water = 31 kg.s <sup>-1</sup>

Rankine cycles utilizing water/steam or organic fluids are the main movers used in these systems. A synopsis of the research on PTC in polygeneration is given in Table 3.

A thermodynamic analysis was performed on an oxyhydrogen combustor powered by a sustainable polygeneration system for remote areas that use solar and wind energy. Electricity, fresh water, hydrogen ( $H_2$ ), oxygen ( $O_2$ ), cooling, water heating, and hot air were continuously produced by the system. The overall energy efficiency and energy efficiency were 50% and 34%, respectively (Luqman et al. 2020). A new hybrid system based on solar and geothermal energy for a building was proposed and assessed. The simulation results showed that the electrolyzer produced  $2.7 \text{ kg}\cdot\text{h}^{-1}$  of hydrogen. The maximum exergy destruction rate occurred in the parabolic trough collector (Khalid et al. 2017). An innovative solar-powered multigeneration system was proposed and examined. The proposed system generated electricity, fresh water, hydrogen, cooling, and household hot water. The findings demonstrated that both energy and exergy efficiency values increased as the turbine input pressure increased (El-Emam et al. 2018). A polygeneration system was proposed and analyzed through energy and exergy assessments. The outputs included hot water, electricity, heating, cooling, dry air, and hydrogen production. The overall energetic and exergetic efficiencies of the system were found to be 70% and 53%, respectively (Sharifishourabi et al. 2017).

The rate of hydrogen production from solar-based polygeneration systems worldwide has shown a steady increase from 2012 to 2024. This growth is largely attributed to advancements in electrolysis technology, enhanced energy management techniques, and increased policy support for green hydrogen. In the initial years (2012–2015), production rates were relatively low, generally below  $0.5 \text{ Nm}^3\cdot\text{h}^{-1}$  per MW of solar capacity, owing to high system costs and inefficient electrolyzers.

From 2016 to 2020, the introduction of proton exchange membrane (PEM) and anion exchange membrane (AEM)

electrolyzers improved compatibility with fluctuating solar inputs, raising production rates to over  $1 \text{ Nm}^3\cdot\text{h}^{-1}$  per MW. The adoption of hybrid systems that combine solar, wind, biomass, or geothermal sources further increased reliability and operational hours.

Since 2020, there has been a notable rise in pilot and commercial-scale projects worldwide, especially in Europe, the Middle East, and the Asia-Pacific region. By 2024, cutting-edge solar-integrated hydrogen systems have reached production rates surpassing  $4 \text{ Nm}^3\cdot\text{h}^{-1}$  per MW, particularly when enhanced with AI-based controls and thermal coupling technologies, such as CPVT–electrolyzer integration. This upward trend is anticipated to persist, driven by the commercialization of next-generation electrolyzers and further decreases in the levelized cost of hydrogen (LCOH).

The graph (Fig. 11) shows a consistent increase in the hydrogen production rate from  $0.2$  to  $4.2 \text{ Nm}^3\cdot\text{h}^{-1}$  per MW between 2012 and 2024, highlighting the rapid advancements in solar-based hydrogen technologies.

An energy and exergy performance analysis of a solar thermal-based polygeneration system that produced electricity, cooling effect, heating effect, and hydrogen was designed and analyzed (Fig. 12). The non-continuous nature of renewable energy sources was addressed by incorporating hot and cold energy storage to operate an organic Rankine cycle and provide cooling at night. The overall energy and energy efficiencies were 20.7% and 13.7%, respectively (Almahdi et al. 2016)

As illustrated in Fig. 13, the system (MSG-1) consists of a solar PTC, a  $s\text{CO}_2$  based Brayton cycle, a transcritical  $\text{CO}_2$  power cycle, a cascade refrigeration system, a PEM electrolyzer, and a hot water tank. The integration of a steam cycle with a potassium-based solar parabolic trough collector enhances the overall energy and exergy efficiency of comprehensive energy systems by 41.9%

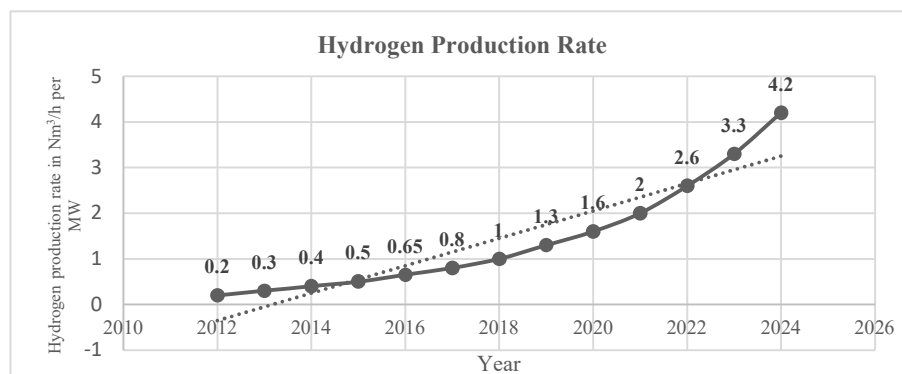

Fig. 11: Hydrogen production rate from solar-based polygeneration systems (2012–2024).



and 26.7%, respectively. Additionally, employing liquid potassium as the working fluid in the parabolic trough collectors boosts the absorbed solar energy input by 419 kW and 2100 kW, leading to a 23% and 90.7% increase in energetic and exergetic efficiency, respectively.

An experimental portable solar power system, a novel polygeneration system, was investigated. This system included photovoltaic panels, an evacuated solar collector, a vapor compression refrigeration, and a desalination unit. The results indicated that approximately 471 W of power was supplied by the photovoltaic panels, and most of the power was consumed by the compressor. In addition, the system could supply 16.5 L of distilled water per hour (Soltani et al. 2023).

A thermodynamic assessment was performed for a self-sustaining multigeneration system that provides the production of drinking water, electricity, and hydrogen (Fig. 14). The plant always produced electricity and potable water simultaneously with an energy supply of 500 kWh per day, while producing a significant amount of freshwater (Cobos Ullvius et al. 2023). The author outlines a novel energy system used to generate different substances, such as electricity, heating, and cooling. It has an overall power capacity of 12839.500 kW for electricity generation, 791.8 kW for heating systems, and 937 kW for cooling systems. The system can further produce 32.92 kg.h<sup>-1</sup> of hydrogen. The system achieves overall energy and exergy efficiencies of 37.68% and 71.25%, respectively (Sharifishourabi et al. 2024).

## Solar Tower-Based MG Systems with Hydrogen Production

An integrated energy system based on renewable resources was examined. When solar energy was unavailable, biomass fuel was utilized as a backup energy source. The system was intended to generate hydrogen, cooling, and power. It had an energy efficiency of 39.99% and an exergy efficiency of 27.47% (El-Emam et al. 2017). The performance of a self-sustaining polygeneration system that was combined with the production of freshwater, power, and hydrogen was analyzed. The system's ability to constantly supply 500 kW and produce a significant amount of freshwater (6500 L per day) was evaluated (Rokni 2019). The effectiveness of a self-sustaining polygeneration system that combined the production of freshwater, electricity, and hydrogen was studied. This system's capacity to generate a significant 6500 L of freshwater per day and deliver 500 kW around-the-clock was evaluated (Cobos Ullvius et al. 2019). An innovative solar-powered intergenerational energy system was investigated. Through electrolysis, the system produces fresh water, heating, cooling, and hydrogen. In addition to producing 90 kg.s<sup>-1</sup> of fresh water and 1.25 kg/h of hydrogen, it was also designed to meet the demand for 4 MW of electricity (El-Emam et al. 2017).

## PV-based MG Systems with Hydrogen Production

Polygeneration microgrids (PMGs) are designed to provide various outputs, including electricity, heat, cold, hydrogen fuel, and clean water as shown in Fig. 15 (Murthy et al. 2020).

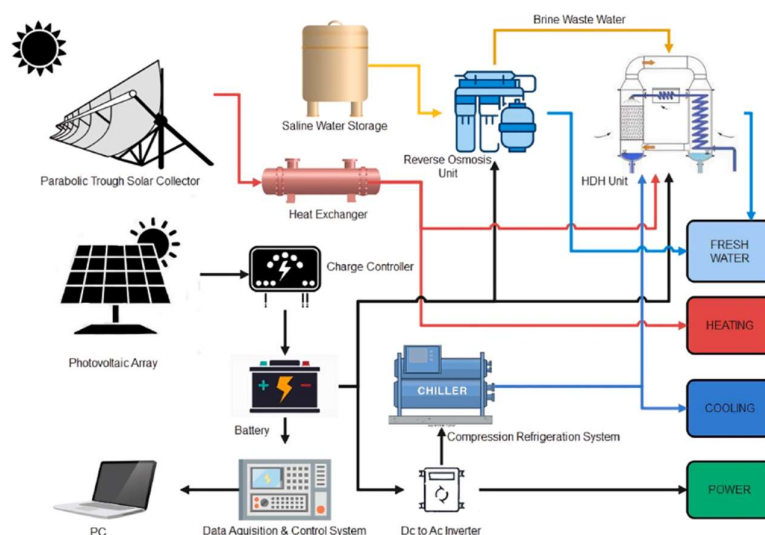

Fig. 14: Integrated solar thermal–photovoltaic multigeneration system for desalination, cooling, heating, and electricity generation (Bamisile et al. 2021).

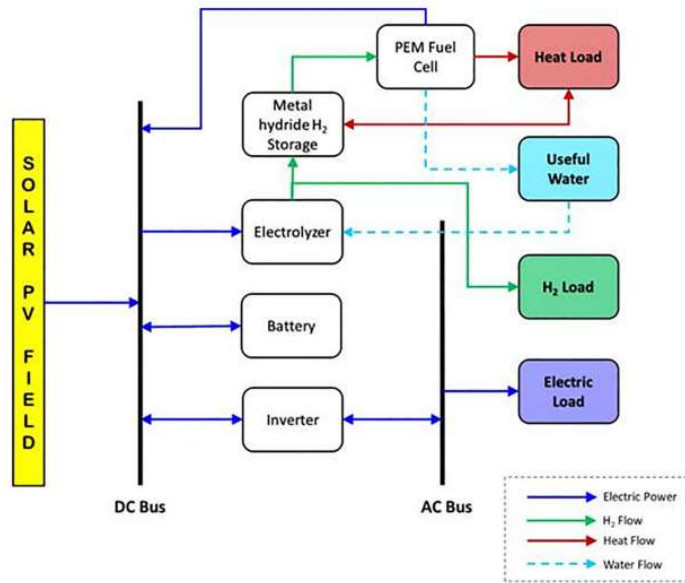

Fig. 15: Solar PV-driven hydrogen energy storage and fuel cell system with DC/AC bus integration (Murthy et al. 2020).

This study optimized a polygeneration unit that provides electricity through a PV array and a digester fueled by animal and agricultural waste. The surplus gas ejected from the digester was used to heat and light the kitchen, and the remaining waste heat was supplied for water filtration using a membrane distillation unit. The outcome indicated that the daily electricity demand could be met without any difficulties from cooking fuel measuring  $0.4 \text{ m}^3$  and drinking water amounting to 2–3 liters at the same time. From an economic perspective, this system was better than any other renewable source (Khan et al. 2015). An analysis of unique polygeneration arrangements for community buildings to address basic energy demands. In all cases, it was assumed that 100% of these five requirements would be met using only renewable energies, namely, PV and PVT panels, as well as biomass backup boiler (BB) solar cells (Uche et al. 2022). In this study, they focused on numerically assessing the energy and economic viability of a novel hybrid polygeneration system fueled by biomass, wind, and solar power, and intended for micro-district residential applications. The results demonstrated that it is possible to create a power generation system that meets user demand for electric power while also fulfilling the needs for cooling, heating, hot domestic water, and freshwater production. Based on the scenarios examined, the economic analysis indicated that the payback period could range from 5.67 to 12.20 years. This signifies that the project is profitable (Figaj et al. 2022).

Analyzed a solar-based polygeneration system thermodynamically. The system delivered an exergy efficiency of 44%. The authors demonstrated that the

system energy efficiency could be improved by 16% with the integration of a cooling system (Islam et al. 2017). Investigated a solar-based CCHP system integrated with a reversible solid oxide fuel cell (R-SOFC). The system used a high-temperature metal hydride (MH) method, which is a chemical-based storage of hydrogen. The system's round-trip energy efficiency was 36% more than that of a single R-SOFC (Lototskyy et al. 2018). As a clean-burning gas, hydrogen does not emit carbon dioxide when burned; therefore, one way to make it available without burning other fuels is to produce it without burning other fuels. Subsequently, other studies on hydrogen generation using renewable sources of energy were conducted. A study of this nature has shown that it is possible to develop several workable strategies for integrating an electrolyzer unit into photovoltaic (PV) panel systems so that hydrogen is produced in an environmentally friendly manner, leading to higher performance of polygeneration facilities (Esmailion et al. 2022). The authors focused on solar, biomass, and wind energy sources to suit the community's different needs. A portion of the power produced by the PV cells is utilized for hydrogen production to run an electrolyzer. The stored hydrogen is then fed to a proton exchange membrane (PEM) fuel cell, which produces additional electricity for EV charging. Biomass is supplied to a gasification unit to obtain hot water and fulfil space heating requirements, as shown in Fig. 16.

An innovative integrated energy system was introduced as shown in Fig. 17, combining three renewable energy sources with both battery and hydrogen storage systems.

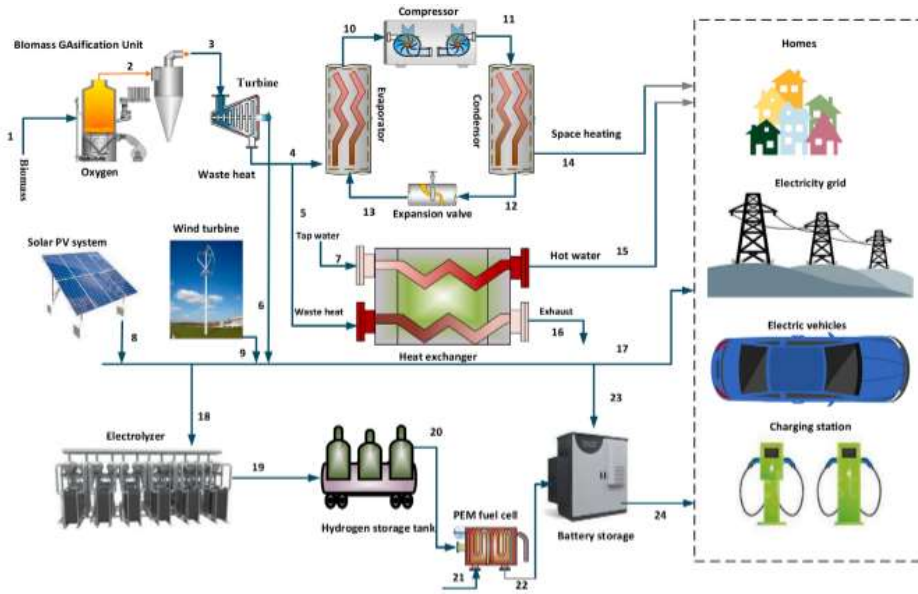

Fig. 16: Schematic of the proposed hybrid polygeneration system (Figaj et al. 2022).

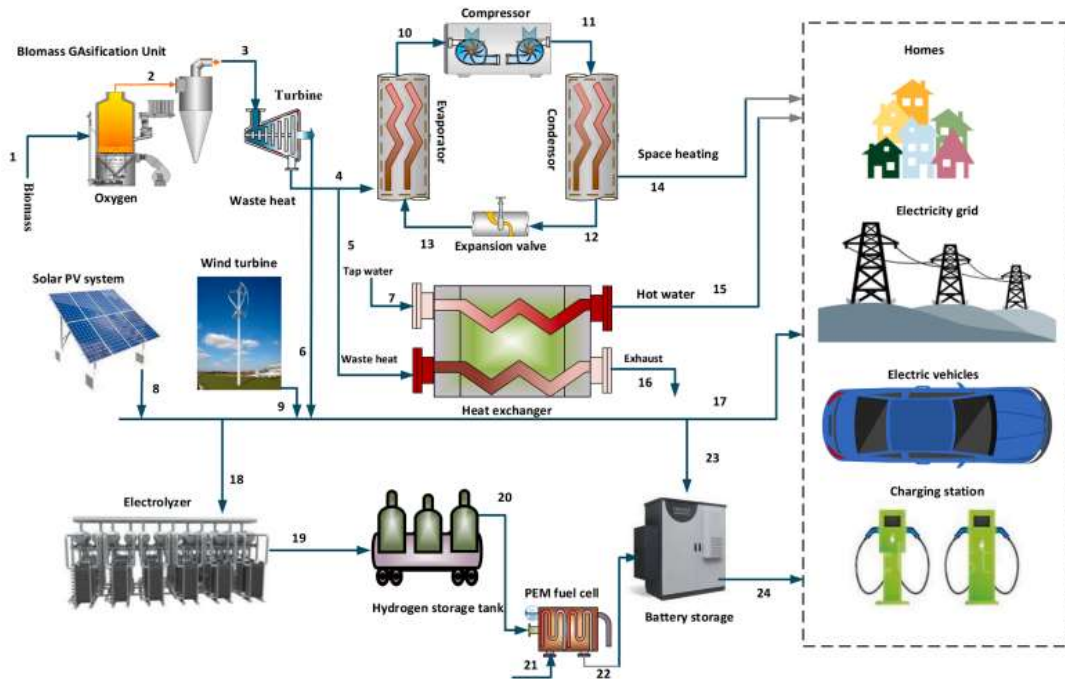

Fig. 17: Schematic layout of the proposed tri-renewable energy system coupled with batteries and hydrogen storage (Ishaq et al. 2024).

Various sensitivity analyses are conducted to illustrate the H<sub>2</sub> storage system's efficiency and practicality. The proportion of the H<sub>2</sub> power-to-power (P2P) solution rises from 18.5% with a photovoltaic (PV) area of 250 m<sup>2</sup> to 45.4% when the PV area is expanded to 500 m<sup>2</sup>. In the charging phase, approximately 25.5 MWh of surplus

solar energy is produced by the PV field. Utilizing a 500 m<sup>2</sup> area can yield 769 kg of hydrogen, which is stored in the hydrogen storage tank, and it can produce 18.4 MWh of energy via the PEM fuel cell. The hydrogen storage outcomes reveal a competitive round-trip efficiency of about 45.5%.

Examined solar-based green hydrogen production system with different configurations of electrolyzer and PV panel. The levelized cost of hydrogen (LCOH) obtained with a mono-crystalline solar PV panel and alkaline electrolyzer was the lowest among the four configurations (Moraba et al. 2025).

### PVT/CPVT-Based MG Systems with Hydrogen Production

#### *Polygeneration Systems With Photovoltaic Thermal Units*

The essential goal of photovoltaic (PV) collectors and photovoltaic/thermal collectors is to enhance electrical and

thermal efficiencies. To overcome the aforementioned issues, these collectors are integrated with other power generation equipment to increase the overall efficiency of a plant. Concentrating thermal photovoltaics (CPVTs) are hybrid solar collectors that generate heat and electricity. These systems typically have a surface covered in PV cells and fluid-filled tubes beneath them to cool the cells, improving their electrical production and providing usable heat. Because concentrators are used, CPVTs can operate at 100°C or higher, making them efficient cogeneration systems. With the addition of a few components, CPVT systems can be converted into trigeneration or polygeneration systems that

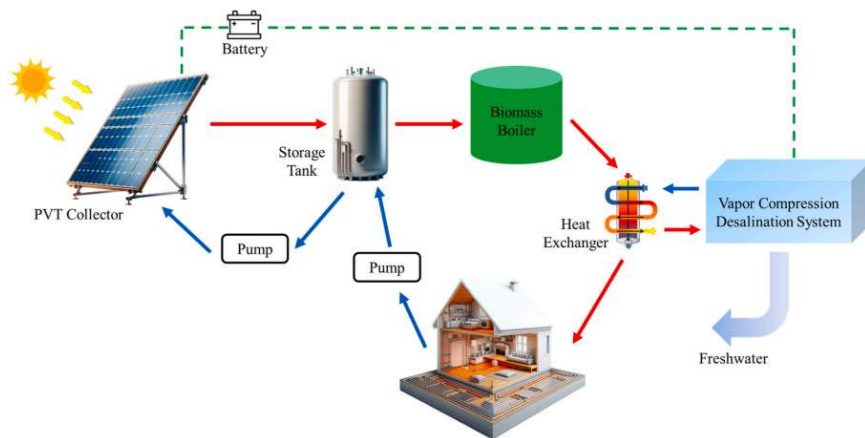

Fig. 18: The schematic of the proposed system (Zhu et al. 2024).

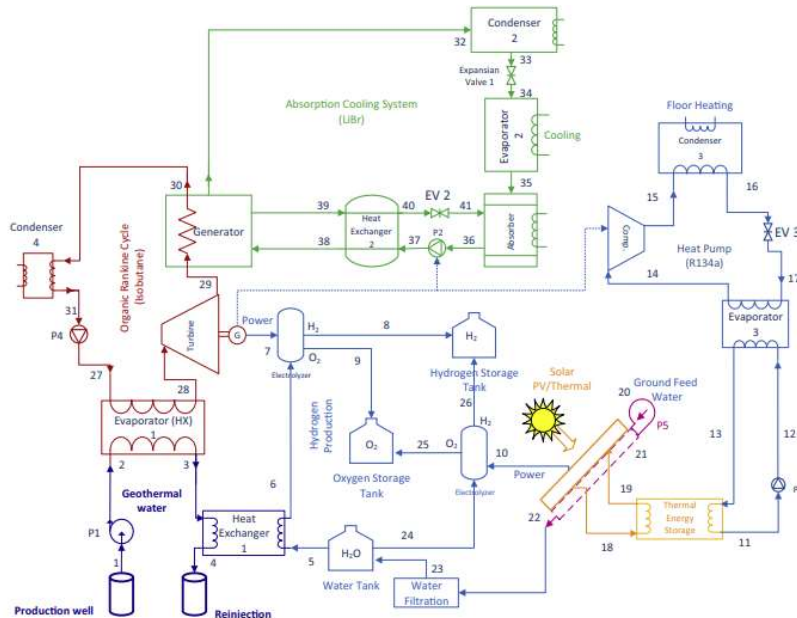

Fig. 19: Integrated geothermal-solar energy system for multigeneration including power generation, cooling, heating, and hydrogen production (Bicer et al. 2016).

produce heat, power, and other useful outputs. They either harness or scatter solar radiation, depending on their shape.

Thus, this section investigates and evaluates polygeneration facilities outfitted with photovoltaic or photovoltaic/thermal collectors.

Proposed an off-grid system as depicted in Fig. 18, that successfully combined a floor heating system with a vapor compression desalination unit to meet electricity, heating, and freshwater requirements. This integration highlights the sustainability and independence of the system from the grid (Zhu et al. 2024).

Proposed novel solar–geothermal hybrid system sources for hydrogen production, power generation, cooling, and heating for practical applications as shown in Fig. 19. It was suggested that the geothermal water temperature

exceeds 210°C, and the system's overall energy and exergy efficiencies will also increase (Bicer et al. 2016).

This study investigated the integration of the Kalina cycle with a concentrated photovoltaic thermal system for multigeneration and hydrogen production. Photovoltaic cells, a Kalina cycle, a hot water tank, a proton exchange membrane electrolyzer, a single-effect absorption system, and a hot air tank were used in the simulations to generate hot water, hydrogen, hot air, power, and cooling. The results revealed that adding the Kalina cycle increased the overall energy efficiency of the multigeneration system from 68.73% to 70.08%. Additionally, the integration of the Kalina system produced an additional 417 kW of electricity, highlighting the significance of this configuration, as shown in Figs. 20a and 20b (Bamisile et al. 2020).

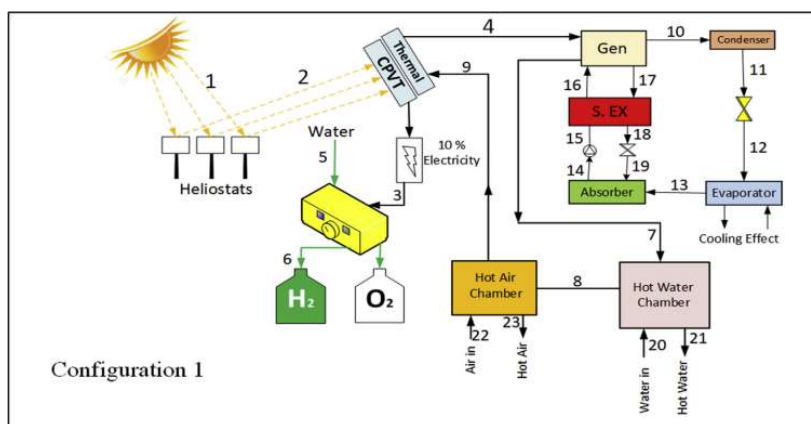

Fig. 20a: CPVT-powered multigeneration system and CPVT integrated with the Kalina cycle multigeneration system schematic diagram (Bamisile et al. 2020).

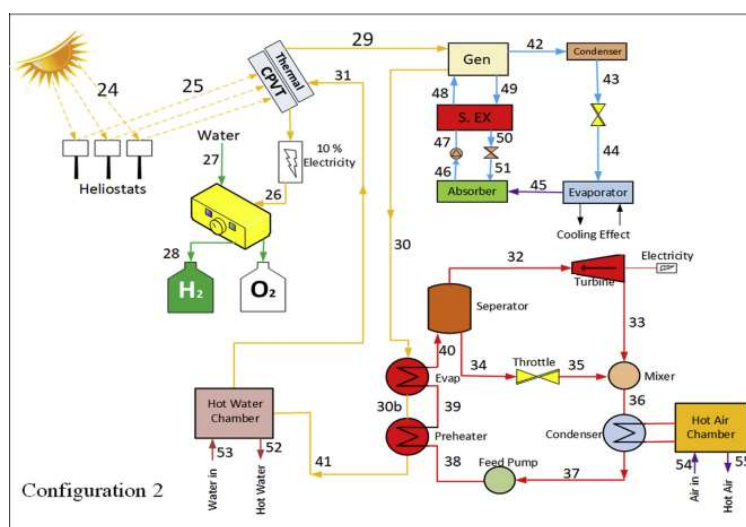

Fig. 20b: CPVT-powered multigeneration system and CPVT integrated with the Kalina cycle multigeneration system. Diagram (Bamisile et al. 2020).

Presented and investigated a novel multigeneration system that combined an ocean thermal energy conversion (OTEC) system with flat plate and PV/T solar collectors. The system also included a reverse osmosis desalination plant for producing freshwater, a single-effect absorption chiller, and a PEM electrolyzer. Thermodynamic evaluation was used to assess the performance of the system. The results revealed an exergy efficiency of 60%, with the system's total cost rate at the time being  $154 \text{ \$}\cdot\text{h}^{-1}$  (Ahmadi et al. 2014). Examined a multi-generation system to meet a building's heating, power, and water needs in St. Petersburg (Russia). The two systems had polygeneration thermal and exergy efficiencies of 48.08% and 31.67% for CES-1, and 59.7% and 43.91% for, respectively (Cai et al. 2020). In this study, two wind-solar-based polygeneration systems, Comprehensive Energy System (CES-1) and CES-2, were assessed to produce hydrogen, hot water, electricity, and cooling. For the conditions in question, the system achieved overall energy and exergy efficiencies of up to 19% and 12%, respectively (Franzese et al. 2020). Proposed and thermodynamically analyzed a novel solar-based system consisting of photovoltaic panels, a photo-electrochemical water splitting reactor, and a fuel cell system for providing electricity and heat to a small community with the option of operating off-grid and producing fresh water. For the conditions in question, the system achieved overall energy and exergy efficiencies of up to 19% and 12%, respectively (Franzese et al. 2020).

Investigated a PV/T powered polygeneration energy system for CCHP & CPHH mode. The results showed that Optimization results highlight the system's strong performance, achieving total energy efficiencies of up to 85.90% and 86.97% for CPHH in spring and winter, and 88.26% for CPCH in summer, with product unit costs as low as  $\$22.21$  per GJ. Also, this research offers valuable insights into developing efficient, renewable energy-integrated multi-generation systems (Wang et al. 2024b). This study investigated a green hydrogen polygeneration system using electrolyzers. The authors suggested that SOEC avoids the inevitable energy loss in AE and PEME. But SOECs are most suitable for high-temperature applications. For general flexibility and integration with renewable energy, PEM electrolyzers are often considered the best option despite their higher cost. Investigated a PVT investigation with emphasis on studies that include environmental issues about PVT technology (Zhang et al. 2023). This work underlined the effect of heat transfer fluid in a PVT system. The study showed that the PVT water system gives better environmental performance than the PVT air system because of its better heat absorption capacity. Also suggested that CPVT systems would be a better replacement of PV cells with a concentrator material, which contributes to cost reduction and less environmental impact (Lamnatou et al. 2017). A biomass and solar integrated system for the multi-generation of useful outputs, combining two renewable energy sources to produce multiple outputs (e.g., power, cooling, hot water,

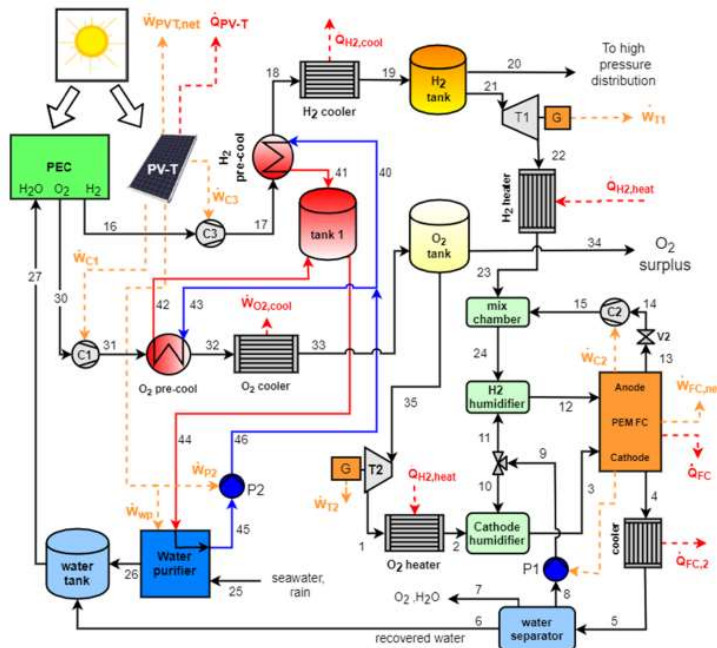

Fig. 21: Schematic diagram of the proposed multigenerational system for hydrogen, power, and district heating (Franzese et al. 2020).

heated air), was developed and presented. The overall energy and exergy efficiencies of the system were determined to be 66.5% and 39.7%, respectively (Khalid et al. 2015). A solar cogeneration system was investigated, and exergy analysis showed that the CPVT is the principal source of exergy destruction. Exergo-economic analysis highlighted the CPVT's economic importance, with a capital investment cost of \$0.08946/h and an exergo-economic efficiency of 28.82% (Akrami et al. 2017). María's economic assessment of an optimized solar combined heating and power system based on a novel PVT collector was investigated. The study found that among the system components, the PVT collector cost had the greatest influence on system economics, accounting for approximately 38% of the total investment. Government incentives, if properly implemented, were shown to improve system economics in the short term. However, in low-latitude locations, these incentives might not be necessary, as high irradiance levels and energy prices contributed to favorable PBTs (Herrando et al. 2018). Presented a dynamic simulation and showed that the system was capable of producing power, heating, cooling, and DHW over the entire year. It was found that from the dynamic simulation results, a significant amount of energy saving can be achieved with PVT, which is coupled to an absorption chiller to meet cooling demand

(Calise et al. 2012). Investigated a solar tri-generation system. The polygeneration system is analyzed to produce electricity and desalinated water. The study provided key suggestions to reduce the SPBs: i) It was found from the study that the optimal ration of solar field area and ACH capacity (at constant MED capacity) around  $5.9 \text{ m}^2.\text{kW}^{-1}$ ; ii) prefer a storage tank with smaller volumes (around

$15 \text{ L.m}^{-2}$ ); iii) finally, exit temperatures from the solar field during summer and winter would be around  $85^\circ\text{C}$  and  $55^\circ\text{C}$  respectively (Calise et al. 2014). Presented a novel solar tri-generation system. The plant was proposed to meet basic energy demands for a small residential building. The results showed that thermal and electrical efficiencies were above 40% and 10%, respectively. The Simple Payback period was found to be 5.36 years; this period decreased to 2.33 years when a capital investment incentive of 30% was available (Calise et al. 2016).

A parametric analysis was conducted on a proposed solar tower-based multi-generation plant for sustainable hydrogen generation using solar energy. The overall energy and exergy efficiencies of the proposed system were 38.66% and 34.14%, respectively. The net power from the system was 8041 kW. Among the components of the cycle, the solar tower had the maximum exergy destruction rate (Yilmaz et al. 2025). This study demonstrates that green hydrogen produced by the portable hybrid system, with its significant calorific value, serves as an eco-friendly fuel alternative. It has the potential to replace traditional fuels, such as LPG, which is commonly used for cooking in rural areas. The system harnesses energy from a micro-hydraulic setup, which can be installed in water bodies with limited volume capacity (Villanueva et al. 2025).

### ***Polygeneration Systems With Hydrogen Production Using Combined Solar Technologies***

Polygeneration systems that integrate hydrogen production with combined solar technologies are designed to produce multiple energy forms, such as electricity, heat, and

Table 4: Comparison table of PVT and CPVT along with hydrogen production systems.

System	Energy Efficiency (%)	Exergy Efficiency (%)	Hydrogen Production Rate	Economic Viability	Limitations
PTC + SOE + CCHP	60–68%	35–45%	$\sim 0.044\text{--}0.107 \text{ kg.h}^{-1}$	Moderate – high capital cost, better with scale	Large land area, thermal losses, and needs thermal storage
Solar Tower + SOE + CCHP	65–75%	40–50%	$\sim 0.0899\text{--}0.161 \text{ kg.h}^{-1}$	Highly feasible at utility scale	High capital cost, complex heliostat field control
PV + PEM + CCHP	50–60%	20–30%	$\sim 0.0267\text{--}0.0623 \text{ kg.h}^{-1}$	Moderate – depends on PV cost and O&M	Low thermal recovery, less efficient hydrogen generation
PVT + PEM + CCHP	70–75%	35–50%	$\sim 0.0719\text{--}0.134 \text{ kg.h}^{-1}$	Improving – dual output adds value	Integration complexity, cost of thermal management
CPVT + PEM + CCHP	75–80%	60–65%	$\sim 0.1078\text{--}0.17 \text{ kg.h}^{-1}$	Promising – high energy yield per area	Thermal management challenges, expensive materials
PTC + SOE + CCHP	60–68%	35–45%	$\sim 0.044\text{--}0.1078 \text{ kg.h}^{-1}$	Moderate – high capital cost, better with scale	Large land area, thermal losses, and needs thermal storage

hydrogen, simultaneously. These systems often combine solar technologies, such as photovoltaic (PV), concentrated solar power (CSP), and solar thermal collectors, with a hydrogen production unit, typically utilizing electrolysis powered by solar electricity. In this process, electricity is used to split water into hydrogen and oxygen, with the hydrogen being stored for future use as a clean energy source. A polygeneration system is proposed that utilizes thermal energy from the ocean. The performance of the system is evaluated thermodynamically, focusing on minimizing the total cost and maximizing the cycle exergy efficiency using an evolutionary algorithm (Ahmadi et al. 2014).

### PCM-Based MG Systems

In recent times, there has been increased attention on multi-generation systems. The integration of PDC-based multigeneration systems with PCMs has primarily been conducted theoretically, with limited experimental studies in this field. Furthermore, most research has focused on specific outputs, such as power, freshwater, and hydrogen. Other frequent outputs and combinations of multigeneration systems with PCM integration have received less research attention (Esfanjani et al. 2024).

A polygeneration system is considered to be one of the most attractive approaches for enhancing energy efficiency and controlling environmental pollution. In all the systems reviewed for polygeneration, the output of one component becomes the input for the subsequent component. In addition, several utility outputs are obtained. In this manner, the amount of useful energy in the given amount of input is harnessed to the maximum extent, thus maintaining a very high energy efficiency (Kamesh et al. 2020). As far as freshwater scarcity is concerned, solar desalination would be the better approach using solar stills or using low-grade heat from any of the components in a multi-generation system to produce fresh water (Girishkumar et al. 2024).

### Techno-Economic Considerations of Solar-Driven Polygeneration Systems with Hydrogen Production

Solar-driven polygeneration systems that produce hydrogen present a comprehensive approach to achieving carbon-neutral energy by generating various outputs, such as electricity, heat, cooling, water, and hydrogen, from solar power. However, their widespread implementation depends on their techno-economic viability.

*Technical Considerations:* These systems boost overall efficiency (up to 70–80%) by harnessing both thermal and electrical solar outputs. The integration with proton exchange membrane (PEM) or solid oxide electrolyzers (SOE) facilitates hydrogen production from variable solar

energy. Configurations, such as CPVT-PEM or solar thermal-SOE, enhance performance; however, they necessitate sophisticated control systems. AI-based energy management is increasingly employed for real-time optimization.

*Economic Considerations:* Capital costs remain substantial, ranging from \$1,000–\$2,500 per kW, due to the requirement for multiple subsystems. Operational expenses, including maintenance and water purification, add 5%–10% of CAPEX annually. The levelized cost of hydrogen (LCOH) has decreased from over \$10/kg in 2012 to \$4–6/kg in 2024, with expectations of reaching \$2–3/kg by 2030, supported by technological advancements and policy incentives.

*Value Enhancement:* The co-production of thermal energy, cooling, and water enhances the return on investment and shortens payback periods to 7–10 years, particularly in off-grid or industrial areas.

*Policy Support and Opportunities:* Incentives for green hydrogen, carbon pricing, and public-private partnerships promote adoption. Despite obstacles, such as high initial investments and infrastructure gaps, opportunities exist in local manufacturing, modular system designs, and digital optimization tools.

## CONCLUSIONS

Solar-powered multigeneration (MG) systems have great potential as environmentally sustainable energy solutions that can resourcefully meet a wide range of energy needs. These systems offer a clean alternative to traditional energy sources and align with the growing global focus on reducing carbon footprints. One of the primary provisions of solar-powered MG installations is the integration of the system to produce hydrogen. This review focuses on hydrogen generation integrated into solar-based polygeneration systems, thereby filling a significant gap in existing research. By investigating this growing mix, the study aims to broaden the understanding and provide significant insights for improving the use of renewable energy technologies.

The present study draws the following conclusions:

- i. Concentrating thermal collectors and hybrid solar technologies, such as PVT or CPVT, are the principal devices for most MG systems. In addition, PV panels and FPCs can be used in some other systems.
- ii. Proton exchange membrane (PEM) electrolysis is considered a more feasible and commonly used approach for hydrogen production than solid oxide electrolysis (SOE) in solar-based polygeneration systems. This preference is attributed to its greater operational flexibility, quicker response time, and ability to work well with the variable nature of solar energy,

making it more suitable for integration into renewable energy systems aimed at achieving carbon neutrality. PEM electrolysis generates hydrogen at a lower cost than alkaline electrolysis, although systems powered by natural gas are more expensive.

- iii. Because of the inherent variability of solar energy, solar-based polygeneration systems frequently include additional renewable sources, such as biomass, geothermal, and wind, to maintain stable operations and continuous hydrogen production, particularly in off-grid or fluctuating-demand situations.
- iv. PTCs offer superior energy and exergy efficiencies, whereas CPVT systems can achieve even higher efficiencies. The highest recorded energy efficiency was 78.93%, with a peak exergy efficiency of 65% for a CPVT-based multigeneration system. In addition, hybrid systems that combine PVs and wind turbines are more economically feasible.
- v. In addition to hydrogen production, useful outputs such as drying, ammonia, hot water, freshwater, heating, cooling, and power can be generated.
- vi. Overall, solar-powered MG systems with integrated hydrogen production show promise as clean energy solutions aligned with sustainability goals; however, further research and development are needed in some areas.

### Future Research Directions and Technical Barriers

To accelerate the adoption of solar-powered polygeneration systems for carbon neutrality, future research should focus on the following key areas:

*Thermal Management in CPVT Systems:* Excess heat can degrade the photovoltaic efficiency of CPVT systems. Advanced cooling techniques, such as heat pipes, liquid cooling, and phase-change materials, are required to maintain thermal stability and optimize energy capture.

*Integration of Intelligent Control Systems:* Future studies should emphasize the use of artificial intelligence and machine learning-based control strategies to dynamically manage energy distribution, optimize the balance between thermal and electrical loads, and enhance hydrogen production efficiency under varying solar input conditions. Advanced thermal management strategies: Efficient heat management in concentrated photovoltaic/thermal (CPVT) systems remains a major challenge. Research should explore innovative heat sink materials, hybrid nanofluids, and phase-change materials (PCMs) to improve thermal regulation and reduce performance degradation.

*Cost and Durability of Hydrogen Subsystems:* Proton exchange membrane (PEM) electrolyzers face issues owing to high initial costs and limited durability under fluctuating solar-powered conditions. Future research should focus on developing cost-effective, non-precious metal catalysts. Improving membrane stability and water management during intermittent operation. Integrating modular, scalable PEM units designed for polygeneration systems.

*System-Level Optimization and Modeling:* Comprehensive system models that incorporate energy, exergy, economic, and environmental (4E) assessments are essential. Coupled optimization of subsystems (e.g., solar field, storage, electrolyzer) using multi-objective algorithms can guide optimal configurations for different climatic zones and user needs. Hybrid Energy Storage Integration: Effectively incorporating hybrid storage systems (thermal, electrical, and chemical) is crucial to mitigate the intermittency of solar resources. The focus should be on developing intelligent energy dispatch algorithms for real-time management of storage-load-production synergy.

*Techno-Economic Feasibility and Policy Support:* More detailed techno-economic analyses are needed to assess long-term viability. Policies should promote modular, off-grid polygeneration units in rural or industrial areas, with localized hydrogen production for mobility or fuel cell applications.

### REFERENCES

- Ahmadi, P., Dincer, I. and Rosen, M.A., 2014. Multi-objective optimization of a novel solar-based multigeneration energy system. *Solar Energy*, 108, pp.576–591, <https://doi.org/10.1016/j.solener.2014.07.022>.
- Akrami, E., Nemati, A., Nami, H. and Ranjbar, F., 2018. Exergy and exergoeconomic assessment of hydrogen and cooling production from concentrated PVT equipped with PEM electrolyzer and LiBr-H<sub>2</sub>O absorption chiller. *International Journal of Hydrogen Energy*, 43(2), pp.622–633. [<https://doi.org/10.1016/j.ijhydene.2017.11.007>]
- Almahdi, M., Dincer, I. and Rosen, M.A., 2016. A new solar based multigeneration system with hot and cold thermal storages and hydrogen production. *Renewable Energy*, 91, pp.302–314, [<https://doi.org/10.1016/j.renene.2016.01.069>].
- Bamisile, O., Huang, Q., Dagbasi, M., Adebayo, V., Okonkwo, E.C., Ayambire, P., Al-Ansari, T. and Ratlamwala, T.A.H., 2020. Thermo-environ study of a concentrated photovoltaic thermal system integrated with Kalina cycle for multigeneration and hydrogen production. *International Journal of Hydrogen Energy*. [<https://doi.org/10.1016/j.ijhydene.2020.07.029>].
- Bamisile, O., Huang, Q., Hu, W., Dagbasi, M. and Kemena, A.D., 2020. Performance analysis of a novel solar PTC integrated system for multi-generation with hydrogen production. *International Journal of Hydrogen Energy*, 45(1), pp.190–206, [<https://doi.org/10.1016/j.ijhydene.2019.10.234>].
- Bamisile, O., Mukhtar, M. and Yimen, N., 2021. Comparative performance analysis of solar powered supercritical-transcritical CO<sub>2</sub> based systems for hydrogen production and multigeneration. *International Journal of Hydrogen Energy*, 46(52), pp.26272–26288, [<https://doi.org/10.1016/j.ijhydene.2021.05.122>].

- Bicer, Y. and Dincer, I., 2016. Development of a new solar and geothermal based combined system for hydrogen production. *Solar Energy*, 127, pp.269–284, [https://doi.org/10.1016/j.solener.2016.01.031].
- Bozgeyik, A., Altay, L. and Hepbasli, A., 2022. A parametric study of a renewable energy based multigeneration system using PEM for hydrogen production with and without once-through MSF desalination. *International Journal of Hydrogen Energy*, 47(74), pp.31742–31754, [https://doi.org/10.1016/j.ijhydene.2022.02.186].
- Cai, D., Bamisile, O., Adebayo, V., Huang, Q., Dagbasi, M., Okonkwo, E.C. and Al-Ansari, T., 2022. Integration of wind turbine with heliostat based CSP/CPVT system for hydrogen production and polygeneration: a thermodynamic comparison. *International Journal of Hydrogen Energy*, 47(5), pp.3316–3345, [https://doi.org/10.1016/j.ijhydene.2020.11.106].
- Calise, F., d'Accadia, M.D. and Vanoli, L., 2012. Design and dynamic simulation of a novel solar trigeneration system based on hybrid photovoltaic/thermal collectors (PVT). *Energy conversion and management*, 60, pp.214–225, [https://doi.org/10.1016/j.enconman.2012.01.025].
- Calise, F., d'Accadia, M.D., Figaj, R.D. and Vanoli, L., 2016. Thermoeconomic optimization of a solar-assisted heat pump based on transient simulations and computer Design of Experiments. *Energy conversion and management*, 125, pp.166–184, [https://doi.org/10.1016/j.enconman.2016.03.063].
- Calise, F., d'Accadia, M.D. and Piacentino, A., 2014. A novel solar trigeneration system integrating PVT (photovoltaic/thermal collectors) and SW (seawater) desalination: Dynamic simulation and economic assessment. *Energy*, 67, pp.129–148, [https://doi.org/10.1016/j.energy.2013.12.060].
- Cobos Ullivius, N. and Rokni, M., 2018. A study on a polygeneration plant based on solar power and solid oxide cells. *International Journal of Hydrogen Energy*, 44(35), pp.19206–19223, [https://doi.org/10.1016/j.ijhydene.2018.04.085].
- El-Emam, R.S. and Dincer, I., 2017. Assessment and evolutionary based multi-objective optimization of a novel renewable-based polygeneration energy system. *Journal of Energy Resources Technology*, 139(1), p.012003, [https://doi.org/10.1115/1.4033625].
- El-Emam, R.S. and Dincer, I., 2018. Development and assessment of a novel solar heliostat-based multigeneration system. *International Journal of Hydrogen Energy*, 43(5), pp.2610–2620, [https://doi.org/10.1016/j.ijhydene.2017.12.026].
- El-Emam, R.S. and Dincer, I., 2018. Investigation and assessment of a novel solar-driven integrated energy system. *Energy Conversion and Management*, 158, pp.246–255, [https://doi.org/10.1016/j.enconman.2017.12.062].
- Esfanjani, P., Mahmoudi, A., Rashidi, S., Valipour, M.S. and Yan, W.M., 2024. A review on phase change material's applications in solar parabolic dish collectors. *Journal of Thermal Analysis and Calorimetry*, 149(23), pp.13533–13549, [https://doi.org/10.1007/s10973-024-13724-1].
- Esmailion, F., Soltani, M., Nathwani, J. and Al-Haq, A., 2022. Design, analysis, and optimization of a novel polygeneration system powered by solar and wind energy. *Desalination*, 543, p.116119, [https://doi.org/10.1016/j.desal.2022.116119].
- Figaj, R., Zoladek, M., Homa, M. and Palac, A., 2022. A novel hybrid polygeneration system based on biomass, wind and solar energy for micro-scale isolated communities. *Energies*, 15(17), p.6331, [https://doi.org/10.3390/en15176331].
- Franzese, N., Dincer, I. and Sorrentino, M., 2020. A new multigenerational solar-energy based system for electricity, heat and hydrogen production. *Applied Thermal Engineering*, 171, p.115085, [https://doi.org/10.1016/j.applthermaleng.2020.115085].
- Girishkumar, G.S., Kamesh, M.R., Rohith, S., Yogaraj, D., Abhilash, M., Sathish, H., Vinayakumar, R. and Somashekar, C., 2024. Modelling and Analysis of a Single Slope Solar Still for Desalination of Water. *Journal of Mines, Metals & Fuels*, 72(4), [https://doi.org/10.18311/jmmf/2024/44523].
- Gursoy, M. and Dincer, I., 2024. Development of a solar ocean based integrated plant with a new hydrogen generation system. *Renewable Energy*, 235, p.121354, [https://doi.org/10.1016/j.renene.2024.121354].
- Herrando, M., Ramos, A. and Zabalza, I., 2018. Cost competitiveness of a novel PVT-based solar combined heating and power system: Influence of economic parameters and financial incentives. *Energy Conversion and Management*, 166, pp.758–777, [https://doi.org/10.1016/j.enconman.2018.04.005].
- Hu, T., Song, Y. and Zhang, X., 2025. A mini review of hydrogen production routes toward carbon neutrality. *Propulsion and Energy*, 1(1), [https://doi.org/10.1007/s44270-024-00004-4].
- Ishaq, M. and Dincer, I., 2024. Investigation of a tri-renewable energy system coupled with battery and hydrogen storages for a sustainable city. *Sustainable Cities and Society*, 104, [https://doi.org/10.1016/j.scs.2024.105291].
- Islam, S., Dincer, I. and Yilbas, B.S., 2017. Development of a novel solar-based integrated system for desalination with heat recovery. *Applied Thermal Engineering*, 129, pp.1618–1633, [https://doi.org/10.1016/j.applthermaleng.2017.09.028].
- Kamesh, M.R., Girishkumar, G.S. and Kajampady, A., 2020. Development of a polygeneration system for a rural community. *IOP Conference Series: Earth and Environmental Science*, 573, p.012044, [https://doi.org/10.1088/1755-1315/573/1/012044].
- Kasaean, A., Bellos, E., Shamaeizadeh, A. and Tzivanidis, C., 2020. Solar-driven polygeneration systems: Recent progress and outlook. *Applied Energy*, 264, p.114764, [https://doi.org/10.1016/j.apenergy.2020.114764].
- Khalid, F., Dincer, I. and Rosen, M.A., 2015. Energy and exergy analyses of a solar-biomass integrated cycle for multigeneration. *Solar Energy*, 112, pp.290–299, [https://doi.org/10.1016/j.solener.2014.11.027].
- Khalid, F., Dincer, I. and Rosen, M.A., 2017. Techno-economic assessment of a solar-geothermal multigeneration system for buildings. *International Journal of Hydrogen Energy*, 42(33), pp.21454–21462, [https://doi.org/10.1016/j.ijhydene.2017.03.185].
- Khan, E.U. and Martin, A.R., 2015. Optimization of hybrid renewable energy polygeneration system with membrane distillation for rural households in Bangladesh. *Energy*, 93, pp.1116–1127, [https://doi.org/10.1016/j.energy.2015.09.109].
- Koc, M., Yuksel, Y.E. and Ozturk, M., 2024. Design and thermodynamic assessment of a novel multigenerational energy system with liquid hydrogen generation. *International Journal of Hydrogen Energy*, 75, pp.144–160, [https://doi.org/10.1016/j.ijhydene.2024.01.074].
- Lamnatou, C. and Chemisana, D., 2017. Photovoltaic/thermal (PVT) systems: A review with emphasis on environmental issues. *Renewable energy*, 105, pp.270–287, [https://doi.org/10.1016/j.renene.2016.12.009].
- Lebepe, M.C., Oviroh, P.O. and Jen, T.-C., 2025. Techno-economic optimisation modelling of a solar-powered hydrogen production system for green hydrogen generation. *Sustainable Energy Research*, 12, [https://doi.org/10.1186/s40807-025-00151-5].
- Lototsky, M., Nyamsi, S.N. and Pasupathi, S., 2018. A concept of combined cooling, heating and power system utilising solar power and based on reversible solid oxide fuel cell and metal hydrides. *International Journal of Hydrogen Energy*, 43(40), pp.18650–18663, [https://doi.org/10.1016/j.ijhydene.2018.05.075].
- Luqman, M., Bicer, Y. and Al-Ansari, T., 2020. Thermodynamic analysis of an oxy-hydrogen combustor supported solar and wind energy-based sustainable polygeneration system for remote locations. *International Journal of Hydrogen Energy*, 45(5), pp.3470–3483, [https://doi.org/10.1016/j.ijhydene.2018.12.191].
- Mahmood, F., Bicer, Y. and Al-Ansari, T., 2021. Design and thermodynamic

- assessment of a solar powered energy–food–water nexus driven multigeneration system. *Energy Reports*, 7, pp.3033-3049, [https://doi.org/10.1016/j.egy.2021.05.032].
- Ministry of New and Renewable Energy (MNRE), 2023. *Annual Report 2022–23: Total electric power installations sector wise from clean energy sources*. Available at: [https://mnre.gov.in/annual-reports-2022-23/]
- Murthy, S.S., Dutta, P., Sharma, R. and Rao, B.S., 2020. Parametric studies on a stand-alone polygeneration microgrid with battery storage. *Thermal Science and Engineering Progress*, 19, p.100608, [https://doi.org/10.1016/j.tsep.2020.100608].
- Ozlu, S. and Dincer, I., 2016. Performance assessment of a new solar energy-based multi-generation system. *Energy*, 112, pp.164–178, [https://doi.org/10.1016/j.energy.2016.06.040].
- Qing, X., 2024. Solar-driven multi-generation system: Thermoeconomic and environmental optimization for power, cooling and liquefied hydrogen production. *Energy*, 293, p.130409, [https://doi.org/10.1016/j.energy.2024.130409].
- Ritchie, H. and Roser, M., 2024. *CO<sub>2</sub> and greenhouse gas emissions dataset*. Our World in Data. Available at: [https://ourworldindata.org/grapher].
- Rokni, M., 2019. Analysis of a polygeneration plant based on solar energy, dual mode solid oxide cells and desalination. *International Journal of Hydrogen Energy*, 44(35), pp.19224–19243, [https://doi.org/10.1016/j.ijhydene.2018.03.147].
- Shabani, M.J. and Babaelahi, M., 2024. Innovative solar-based multi-generation system for sustainable power generation, desalination, hydrogen production and refrigeration in a novel configuration. *International Journal of Hydrogen Energy*, 59, pp.1115–1131, [https://doi.org/10.1016/j.ijhydene.2024.02.023].
- Sharifishourabi, M., Dincer, I. and Mohany, A., 2024. Advancing energy transition with novel biomass–solar based multi-generation energy system using hydrogen and storage options for sustainable cities. *Sustainable Cities and Society*, 108, [https://doi.org/10.1016/j.scs.2024.105457].
- Sharifishourabi, M., Ratlamwala, T.A.H., Alimoradiyan, H. and Sadeghizadeh, E., 2017. Performance assessment of a multi-generation system based on organic Rankine cycle. *Iranian Journal of Science and Technology, Transactions of Mechanical Engineering*, 41, pp.225–232, [https://doi.org/10.1007/s40997-016-0057-x].
- Soltani, M., Hajizadeh Aghdam, A. and Aghaziarati, Z., 2023. Design, fabrication and performance assessment of a novel portable solar-based polygeneration system. *Renewable Energy*, 202, pp.699–712, [https://doi.org/10.1016/j.renene.2022.10.119].
- Temiz, M. and Dincer, I., 2024. Design and analysis of a concentrated solar power-based system with hydrogen production for a resilient community. *Energy*, 307, p.132628, [https://doi.org/10.1016/j.energy.2024.132628].
- Tukenmez, N., Koc, M. and Ozturk, M., 2020. Development and performance analysis of a concentrating collector combined plant for multigeneration purposes. *Energy Conversion and Management*, 205, p.112415, [https://doi.org/10.1016/j.enconman.2019.112415].
- Uche, J., Zabalza, I., Gesteira, L.G., Martínez-Gracia, A. and Usón, S., 2022. A sustainable polygeneration system for a residential building. *Applied Sciences*, 12, p.12992, [https://doi.org/10.3390/app122412992].
- Villanueva, E.A., Canales, P.I., Paccori, M.M., Tueros, J.C. and Hinostroza, K.I., 2025. Portable hybrid system for producing green hydrogen by electrolysis using energy generated through an Archimedean screw. *Nature Environment and Pollution Technology*, 24(2), pp.1–17, [https://doi.org/10.46488/NEPT.2025.v24i02.D1658].
- Wang, G., Zhang, Z. and Lin, J., 2024a. Multi-energy complementary power systems based on solar energy: A review. *Renewable and Sustainable Energy Reviews*, 199, p.114464, [https://doi.org/10.1016/j.rser.2024.114464].
- Wang, P., Li, Q., Wang, S. and Hui, B., 2024b. A multi-generation system with integrated solar energy combining energy storage, cooling, heat and hydrogen production functionalities: Mathematical model and thermo-economic analysis. *Renewable Energy*, 230, p.120812, [https://doi.org/10.1016/j.renene.2024.120812].
- Yilmaz, F., Ozturk, M. and Selbas, R., 2025. Proposal of an advanced hybrid multigeneration plant using solar energy for sustainable hydrogen generation: A thermodynamic and environmental analysis. *Renewable Energy*, 243, p.122621, [https://doi.org/10.1016/j.renene.2025.122621].
- Zhang, S. and Zhang, N., 2023. Review on integrated green hydrogen polygeneration systems: Electrolysers, modelling, 4E analysis and optimization. *Journal of Cleaner Production*, 414, p.137631, [https://doi.org/10.1016/j.jclepro.2023.137631].
- Zhu, J., Nutakki, T.U.K., Singh, P.K., Abdullaeva, B.S., Zhou, X., Fouad, Y. and Alzubaidi, L.H., 2024. Sustainable off-grid residential heating and desalination: Integration of biomass boiler and solar energy with environmental impact analysis. *Journal of Building Engineering*, 87, [https://doi.org/10.1016/j.job.2024.109035].